

# Filtration, Separation & Purification Solutions for Biopharma Applications

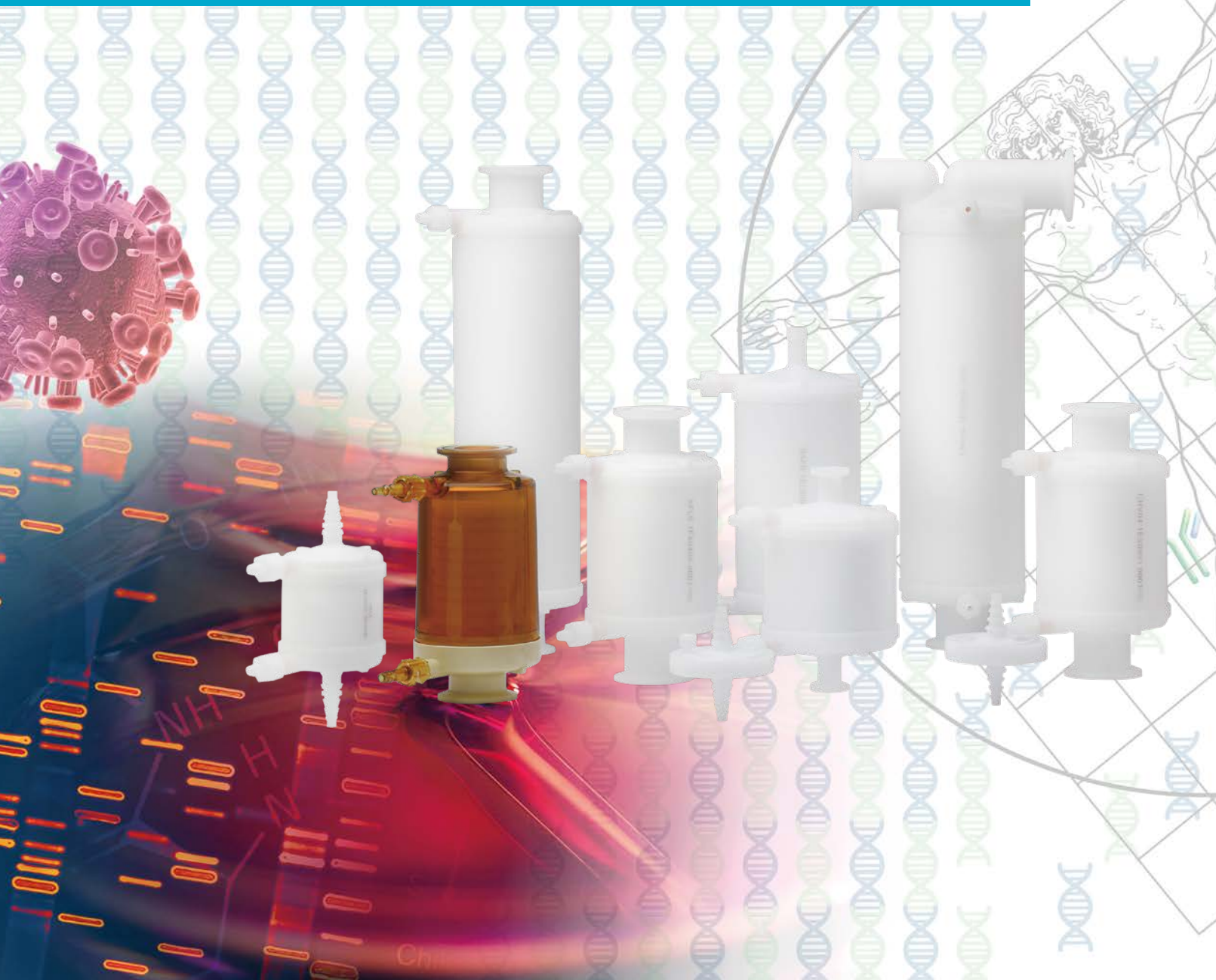

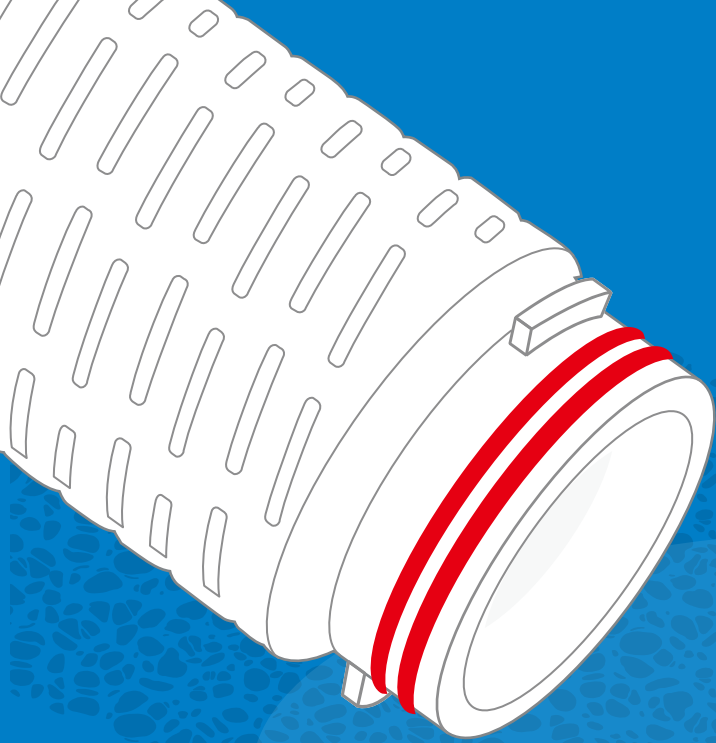

# Filtration Separation Purification



Cobetter dedicates itself to providing Filtration, Separation, & Purification

Solutions for bio-pharmaceutical processes. Cobetter provides over **6,200+** process validation reports for customers in the pharmaceutical industry (2023),

and provided over **2,500+** technical analysis reports for customers in the microelectronic, chemical and life science industry.



Filtration, Separation & Purification  
Solutions for Biopharma Applications





**Membrane Manufacturing**



**Filter Manufacturing**



**AVL Center**



**Housing Manufacturing**

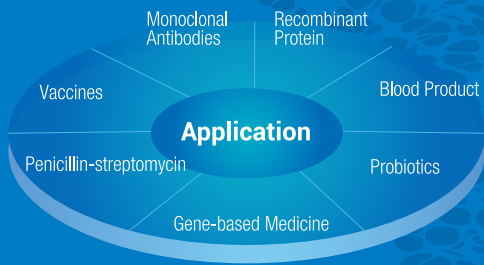
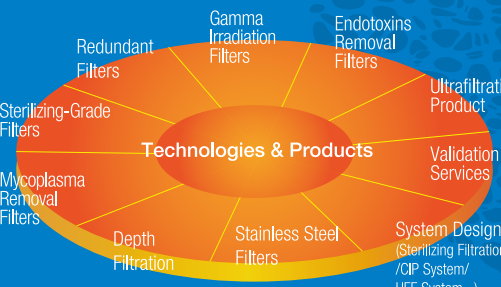

**C11** Semiconductor Ultra-pure water Degassing Membrane  
66500 SQM, 2025

**C12** Biopharma Filtration Products Manufacturing Center  
60000 SQM, 2025.6

**C8** Cobetter R&D Headquarters

**C9** ECMO Membrane Manufacturing Center

**C10** Virus Clearance Validation Services Center  
Newtron Bioassay Co.,Ltd



**C1** Factory Membrane Filter Manufacturing  
9400 SQM

**C3** Semiconductor & Biological Filter Manufacturing  
13500 SQM

**C5** Application & Validation Laboratory Center Biopharm Single-Use Manufacturing  
41,000 SQM

**C7** Diagnostic Product R&D Center  
1300 SQM

**C2** Factory Depth Filter Manufacturing  
9000 SQM

**C4** Factory Stainless Filter Manufacturing & Fluoroplastics Resurtech Manufacturing & Housing Manufacturing  
28000 SQM

**C6** Living Quarters  
33000 SQM

Filtration, Separation & Purification Solutions for Biopharma Applications





**Validation Expert**  
 Taketomi Hidetoshi, Japanese  
 Previous Pall Lab Expert for  
 More Than 30 Years.

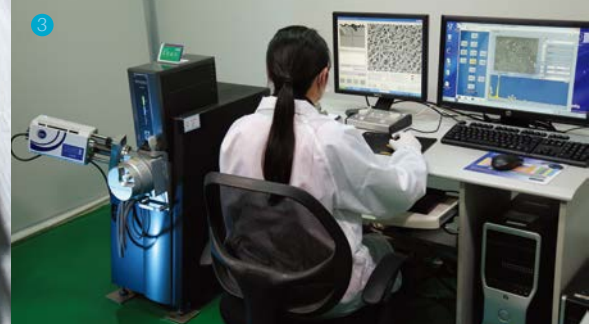

# AVL Center

Accredited by China National Accreditation Service for Conformity (CNAS)  
 Established with an initial 21million USD investment



ISO 17025

1000+ Equipments  
 480+ SOP  
 350+ Engineers



## Life & Science Validation Center

- ①⑥ **Bacterial Challenge Test** : Retention tests for Mycoplasma, B.diminuta, Serratia marcescens, lactobacillus, saccharomycetes, colibacillus and other microorganisms
- Chemical Analysis** : Extractable & Leachables , Chemical Compatibility test
- UV/PDA-HPLC** : UV/PDA scanning to determine extractables and leachables
- ④ **UPLC/MS** : Determine the nonvolatile and semivolatile of extractable & leachables quantitatively and qualitatively
- ⑤ **GC-MS** : Determine volatile/semi-volatile status of extractables and leachables quantitatively and qualitatively
- ② **IC/ICP-MS** : Analyze alkalis, halogen family, acid radicals, ammonia, and other ions quantitatively
- NVR** : Analyze non-volatile extractable from water, IPA, Acetone and other volatile solutions quantitatively
- FTIR** : Analyze polymers and oligomers in non-volatile extractable & leachables qualitatively
- ③ **SEM/EDS** : Analyze filter membrane defect, appearance, and impurities. SEM analysis of chemical compatibility



Filtration, Separation & Purification  
 Solutions for Biopharma Applications



# Advanced Quality Control Methods

## Ensure that Every Product is Safe, Reliable, and Stable

**Quality Assurance is based on the Quality Assurance System**  
 - Focus on the Production Process

**Implement 4M Quality Management Concept**  
 - Process and System Simultaneous Completion

**All Products are based on the QC Project Table**  
 - Produced as per SOP for Stable Production



# 4M Manufacture

Input

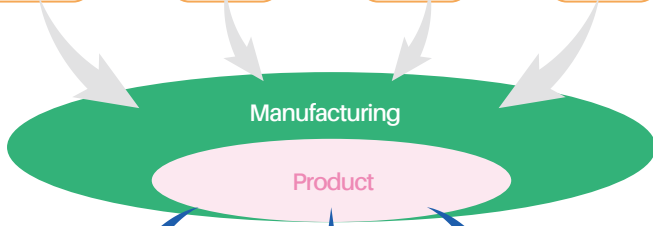
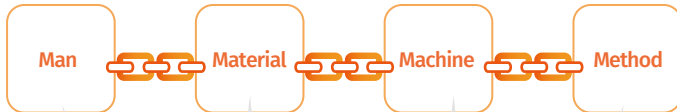

3 Elements of the Products



Output



Filtration, Separation & Purification  
 Solutions for Biopharma Applications



# Flow Diagram of Bioprocess

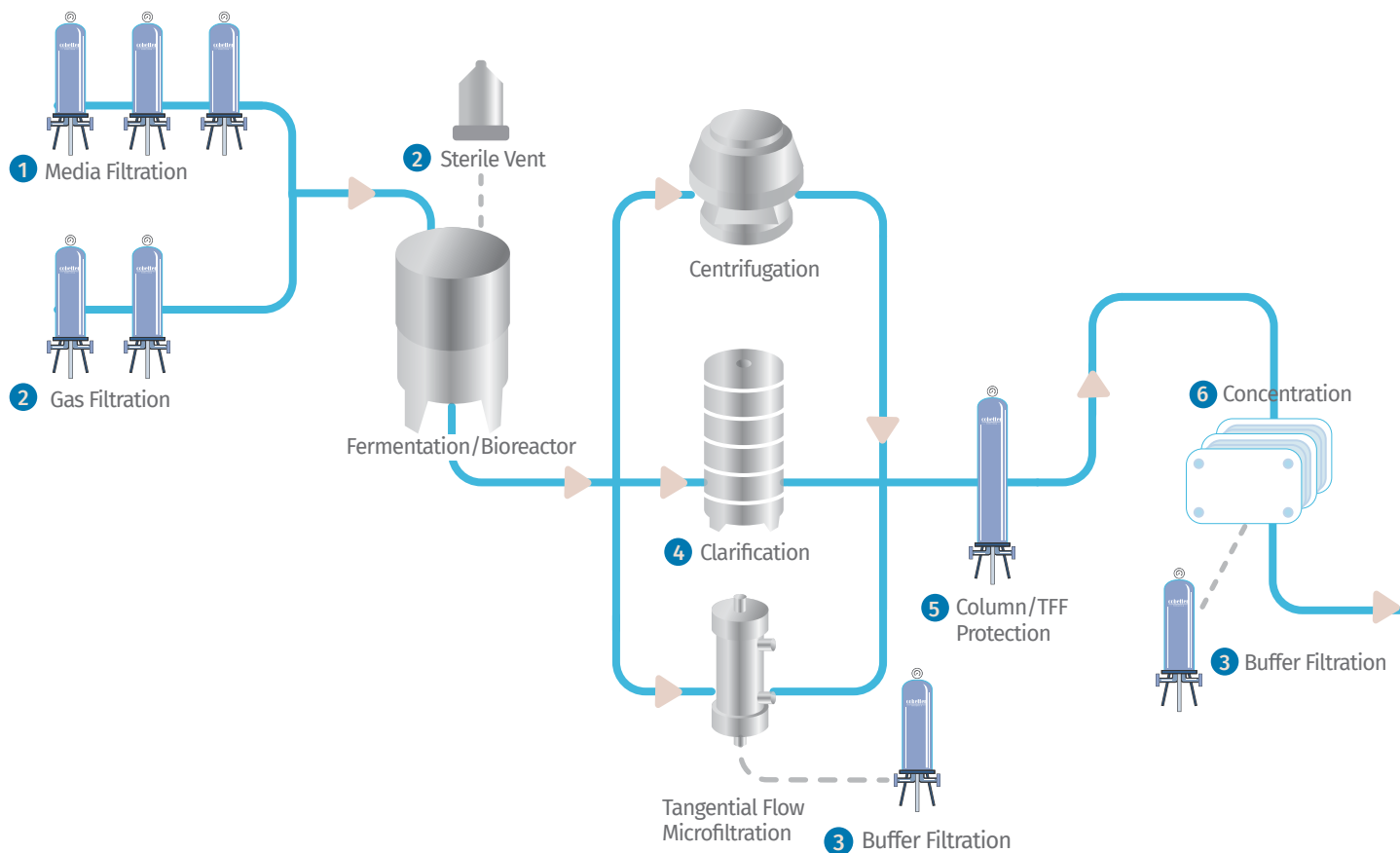

## 1 Media Filtration

Prefiltration

-Purcise PECL -PES

Sterilizing-grade Filtration

-Purcise SLT -PES

Mycoplasma Removal Filtration

-Purcise MEC -PES

## 2 Vent and Gas Filtration

-Safesure AFBB -Hydrophobic PTFE

-Safesure AFM -Hydrophobic PTFE

-Aegivast ACE -Hydrophobic PTFE

-Corevital APB -Hydrophobic PVDF

## 3 Buffer Filtration

Prefiltration

-Safetect PME -PES

-Purcise PLE -PES

-Purcise PAF -PES

-Corevital PMD -PVDF

-Corevital PDF -PVDF

-Corevital PND -PVDF

Sterilizing-grade Filtration

-Purcise SAF -PES

-Corevital SND -PVDF

-Corevital SMD -PVDF

## 4 Clarification Filtration

-Roheap CSD

-Claricap CSD

## 5 Column / TFF Protection

Clarification

-Greclary CHV -Glass Fiber

-Excesal CHE -PP

-Excesal CHT -PP

Bioburden Reduction and Particle Control

-Purcise PLE -PES

-Safetect PME -PES

-Corevital PMD -PVDF

-Corevital PDF -PVDF

-Corevital PND -PVDF

Sterilizing-grade Filtration

-Purcise SLE -PES

## 6 Concentration and Purification

-Consieve UET -PES

-Consieve UFC -RC

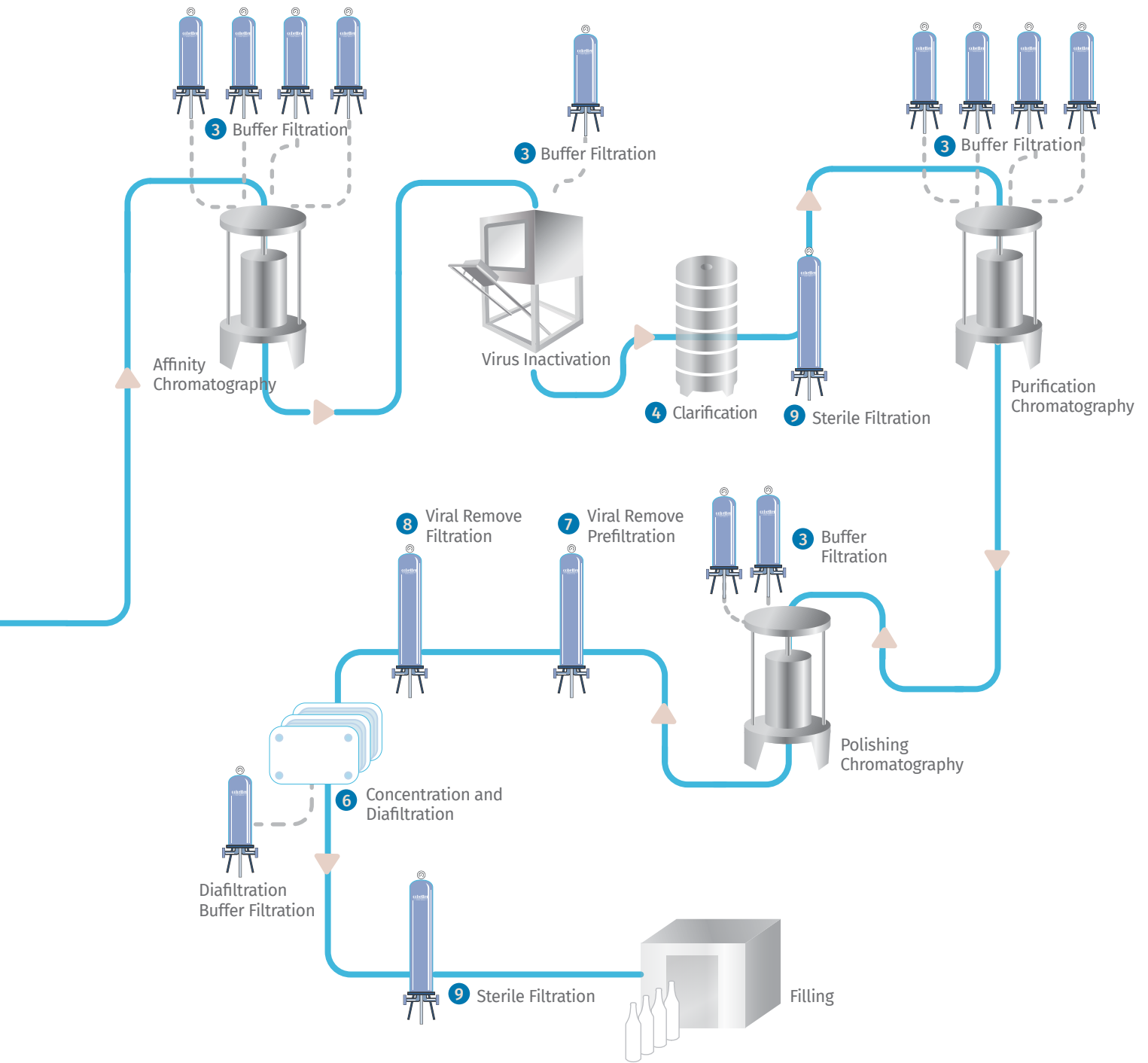

## 7 Viral Remove Prefiltration

- Corevital SMD -PVDF
- Viruclear PNY -Nylon
- Viruclear PDT -Depth Filter

## 8 Virus Clearance

- Viruclear VF PLUS -PES
- Viruclear VF PLUS X -PES
- Viruclear RC -RC
- Viruclear RC H-RC

## 9 Sterile Filtration

- Purcise SLE -PES
- Purcise SLT -PES
- Purcise SBV -PES
- Purcise SEAS -PES
- Corevital SND -PVDF
- Corevital SVLB -PVDF
- Corevital SMD -PVDF

# Bricap & Brisip Capsule Filter Series



## Bricap/BriScale Disc Capsule Filters

| Format              | Diameter | Max. Length | Inlet/Outlet                          | Vent      |
|---------------------|----------|-------------|---------------------------------------|-----------|
| <b>Bricap V50D</b>  | 64mm     | 70mm        | 6-13 mm (1/4"-1/2") Stepped Hose Barb | N/A       |
| <b>Bricap V50A</b>  | 73mm     | 74mm        |                                       | N/A       |
| <b>Bricap V42</b>   | 56mm     | 47mm        | 6-9 mm (1/4"-3/8") Stepped Hose Barb  | N/A       |
| <b>BriScale A50</b> | 64mm     | 71mm        | 6-13mm(1/4"-1/2") Stepped Hose Barb   | Luer lock |



## Bricap C/D Series Capsule Filters

| Format            | Diameter | Max. Length | Inlet/Outlet  | Vent/Drain    |
|-------------------|----------|-------------|---|---------------|
| <b>Bricap C01</b> |          | 106mm       | 14 mm (9/16") Sanitary Flange<br>19 mm (3/4") Sanitary flange   |               |
| <b>Bricap C02</b> | 64mm     | 136mm       | 31 mm (1 1/4") Sanitary Flange                                  | 6mm Hose Barb |
| <b>Bricap C03</b> |          | 173mm       | 6-13 mm (1/4"-1/2") Stepped Hose Barb<br>9.6mm (3/8") Hose Barb |               |



## Brisip Series Capsule Filters

| Format            | Diameter | Max. Length | Inlet/Outlet                   | Vent/Drain               |
|-------------------|----------|-------------|--------------------------------|--------------------------|
| <b>Brisip SP3</b> | 81mm     | 159mm       | 38 mm (1 1/2") Sanitary Flange | 6mm Hose Barb<br>Stäubli |



## Bricap L Series Capsule Filters

| Format            | Diameter | Max. Length | Inlet/Outlet  | Vent/Drain    |
|-------------------|----------|-------------|---|---------------|
| <b>Bricap L02</b> |          | 142mm       |   |               |
| <b>Bricap L03</b> |          | 190mm       | 14 mm (9/16") Sanitary Flange<br>19 mm (3/4") Sanitary flange<br>38 mm (1 1/2") Sanitary Flange |               |
| <b>Bricap L05</b> | 89mm     | 233mm       | 13 mm (1/2") Hose Barb  | 6mm Hose Barb |
| <b>Bricap L10</b> |          | 347mm       | 14 mm (9/16") Hose Barb   |               |
| <b>Bricap L20</b> |          | 585mm       | 16 mm (5/8") Hose Barb  |               |
| <b>Bricap L30</b> |          | 838mm       | 19 mm (3/4") Hose Barb<br>25 mm (1") Hose Barb  |               |



## Bricap T Series Capsule Filters

| Format            | Diameter                 | Max. Length | Inlet/Outlet                   | Gauge Port                     | Vent/Drain    |
|-------------------|--------------------------|-------------|--------------------------------|--------------------------------|---------------|
| <b>Bricap T10</b> |                          | 354mm       | 38 mm (1 1/2") Sanitary Flange | 14 mm (9/16") Sanitary Flange  |               |
| <b>Bricap T20</b> | 89mm                     | 592mm       | 19mm (3/4") Hose Barb          | 38 mm (1 1/2") Sanitary Flange | 6mm Hose Barb |
| <b>Bricap T30</b> | /152mm<br>(Inlet/Outlet) | 845mm       | Hose Barb                      | No top port                    |               |

## Inlet /Outlet Connections

**C** Female Luer Lock Inlet



**P** Male Luer Lock Outlet



**K** 14 mm (9/16") Sanitary Flange

**T** 19 mm (3/4") Sanitary Flange



**F** 31 mm (1 1/4") Sanitary Flange

**S** 38 mm (1 1/2") Sanitary Flange



**Y** 9.6 mm (3/8") Single Stepped Hose Barb

**H** 13 mm (1/2") Single Stepped Hose Barb

**V** 14 mm (9/16") Single Stepped Hose Barb

**X** 16 mm (5/8") Single Stepped Hose Barb

**M** 19 mm (3/4") Single Stepped Hose Barb

**D** 25 mm (1") Single Stepped Hose Barb



**B** 6-13 mm (1/4"-1/2") Multiple Stepped Hose barb

**E** 6-9 mm (1/4"-3/8") Multiple Stepped Hose barb



**S-S** 38 mm (1 1/2") Sanitary Flange (Only for T-Type Capsule)





## Filter Cartridge

| Nominal Length | Adaptor         | Seal Material                 |
|----------------|-----------------|-------------------------------|
| 5"             | 226/Fin         | Silicone                      |
| 10"            | 226/Flat        | EPDM                          |
| 20"            | 222/Fin         | Fluoroelastomer               |
| 30"            | 222/Flat        | FEP/ PFA encapsulated O-rings |
| 40"            | Double Open End |                               |



# Catalog

## Sterilizing-Grade Filter Series

**Purcise SAF Filter** P 11  
Hydrophilic Sterilizing-Grade Filter with High Flow Rate

**Purcise SLE Filter** P 13  
Hydrophilic Sterilizing-Grade Filter with Low Protein Adsorption

**Purcise SLEB Filter** P 17  
Hydrophilic Sterilizing-Grade Filter with Low Protein Adsorption

**Purcise SLTS Filter** P 21  
Sterilizing-Grade Filter with Low Adsorption

**Purcise SBVS Filter** P 23  
Sterilizing-Grade Filter

**Purcise SEAS Filter** P 27  
Sterilizing-Grade Filter

## Mycoplasma Removal Filter Series

**Purcise MLE Filter** P 29  
Hydrophilic Filter with High Mycoplasma Retention Rate

**Purcise MEC Filter** P 33  
Hydrophilic Filter with High Mycoplasma Retention Rate

## Prefiltration and Bioburden Reduction Series

**Safetect PME Filter** P 37  
Hydrophilic Filter with High Dirt-Holding Capacity

**Purcise PLE Filter** P 39  
Hydrophilic Filter with Low Protein Adsorption

**Purcise PAF Filter** P 41  
Hydrophilic Filter with High Flow Rate

**Purcise PEHS Filter** P 43  
Hydrophilic Filter with High Flow Rate

**Purcise PEAB Filter** P 45  
Hydrophilic Filter with High Flow Rate

**Purcise PECL Filter** P 49  
Hydrophilic Filter with High Flow Rate

## Sterilizing-Grade Filter Series

**Corevital SND Filter** P 53  
Hydrophilic Sterilizing-Grade Filter with Low Protein Adsorption

**Corevital SMD Filter** P 56  
Hydrophilic Sterilizing-Grade Filter with High Throughput and Low Protein Adsorption

**Corevital SVLB Filter** P 61  
Hydrophilic Sterilizing-Grade Filter with High Throughput and Low Protein Adsorption

## Prefiltration and Bioburden Reduction Series

**Corevital PMDS Filter** P 65  
Hydrophilic Filter with Low Protein Adsorption

**Corevital PDFS Filter** P 67  
Hydrophilic Filter with Low Protein Adsorption

**Corevital PNDS Filter** P 69  
Hydrophilic Filter with High Throughput and Low Protein Adsorption

## Mycoplasma Removal Filter Series

**Corevital MMDA Filter** P 73  
Hydrophilic Filter with High Mycoplasma Retention Rate

## Sterilizing-Grade Filter Series

**Safesatable SHBB Filter** P 77  
Hydrophilic Sterilizing-Grade Filter

## Gas Filtration Series

**Corevital APB Filter** P 81  
Gamma-Resistant Hydrophobic Filter

**Safesure AFBB Filter** P 84  
Hydrophobic Filter

**Safesure AFM Filter** P 87  
Hydrophobic Sterilizing-Grade Filter with High Retention Rate and High Throughput

**Aegivast ACE Filter** P 91  
Hydrophobic Filter with High Retention Rate

## Clarification Filter Series

**Excesal CHT Filter** P 93  
Clarification Filter with High Dirt-Holding Capacity

**Excesal CHE Filter** P 96  
Clarification Filter with High Retention Rate

**Greclary CHV Filter** P 99  
High Throughput Filter

## Sterilizing-Grade Filter Series

# Purcise SAF Filter

## Hydrophilic Sterilizing-Grade Filter with High Flow Rate



PES membrane with asymmetric pore size provides high dirt-holding capacity, realizing the combination of high throughput and high loading capacity.

### Features

High loading and throughput  
Reliable retention of bacteria and particles  
Extensive chemical compatibility

### Typical Applications

Buffer filtration, process fluids sterile filtration  
Pre-column/ultra-filtration protection  
Filtration of intermediate products/stock solutions  
Filtration of terminal products

### Quality Control

100% integrity testing in manufacturing  
Each filter is fully traceable with unique serial number  
ISO 9001:2015 manufacturing facility

### Removal Rating and Effective Filtration Area

|                                 | SAFN(0.2 µm)        | SAFS(0.45/0.2 µm)   | SAFH(0.65/0.2 µm)   |
|---------------------------------|---------------------|---------------------|---------------------|
| A - Standard Cartridge (10")    | 0.55 m <sup>2</sup> | 0.55 m <sup>2</sup> | 0.55 m <sup>2</sup> |
| H - High Area Cartridge 1 (10") | 0.8 m <sup>2</sup>  | 0.8 m <sup>2</sup>  | 0.8 m <sup>2</sup>  |
| L - High Area Cartridge 2 (10") | 1.04 m <sup>2</sup> | 1.04 m <sup>2</sup> | 1.04 m <sup>2</sup> |

### Materials of Construction

|                           |   |
|---------------------------|---|
| Membrane                  | Hydrophilic polyethersulfone (PES)                              |
| Support                   | Polypropylene (PP)  |
| Core/Cage/End Caps        | Polypropylene (PP)  |
| Cartridge End Cap Inserts | Polybutylene terephthalate (PBT)<br>(Cartridge exclusive)       |
| Cartridge End Cap O-rings | Silicone / EPDM / Fluoroelastomer /<br>PFA encapsulated O-rings |
| Capsule Housing           | Polypropylene (PP)  |
| Capsule Vent O-rings      | Silicone  |
| SP3 Capsule Port Insert   | 316L Stainless Steel  |
| SP3 Capsule Housing       | Polyetherimide (PEI)  |
| SP3 Capsule O-rings       | Silicone  |

### Maximum Differential Pressure

|                           |  |
|---------------------------|--|
| A - Standard Cartridge/   | Forward: 0.69 MPa @ 25 °C, 0.40 MPa @ 60 °C, 0.24 MPa @ 80 °C  |
| H - High Area Cartridge 1 | Reverse: 0.30 MPa @ 25 °C, 0.10 MPa @ 80 °C  |
| L - High Area Cartridge 2 | Forward: 0.55 MPa @ 25 °C, 0.40 MPa @ 60 °C, 0.24 MPa @ 80 °C<br>Reverse: 0.30 MPa @ 25 °C, 0.10 MPa @ 80 °C |
| Capsule                   | Forward: 0.55 MPa @ 25 °C, 0.1 MPa @ 80 °C<br>Reverse: 0.21 MPa @ 25 °C                                      |

### Integrity Test Standards

|  |  |
|--|--|
| Standard - 10inch<br>(0.55m <sup>2</sup> ) | Bubble Point @20 °C ≥ 0.32 MPa, air, wetted with water<br>Air Diffusion @20 °C ≤ 28 ml/min @0.275 MPa, wetted with water |
| Q Series - 10inch<br>(0.55m <sup>2</sup> ) | Bubble Point @20 °C ≥ 0.39 MPa, air, wetted with water<br>Air Diffusion @20 °C ≤ 28 ml/min @0.275 MPa, wetted with water |

### Sterilization

|  |  |
|--|--|
| A - Standard Cartridge/<br>H - High Area Cartridge 1 | Can be steam sterilized for 30 minutes at 135 °C with 50 cycles (< 30 kPa)<br>Can be autoclaved 50 cycles for 30 minutes at 130 °C   |
| L - High Area Cartridge 2                            | Can be steam sterilized for 30 minutes at 135 °C with 30 cycles (< 30 kPa)<br>Can be autoclaved 30 cycles for 30 minutes at 130 °C   |
| Capsule  | Autoclavable capsules only: Can be autoclaved 25 cycles for 30 minutes at 130 °C, (Can not be steam sterilized in-line)<br>Gamma compatible capsules: Can be sterilized by gamma irradiation at 25-45 kGy or can be autoclaved 5 cycles for 60 minutes at 126 °C. (Can not be steamed in-line)<br>Sterile capsule: Can be sterilized by gamma irradiation at 25-45 kGy<br>Cleansteam bag sterile package: Pre-sterilized with autoclave for 30 minutes at 121 °C |

Notes: Gamma sterilized products cannot be re-sterilized with gamma irradiation or steam sterilization



## Flow Rates

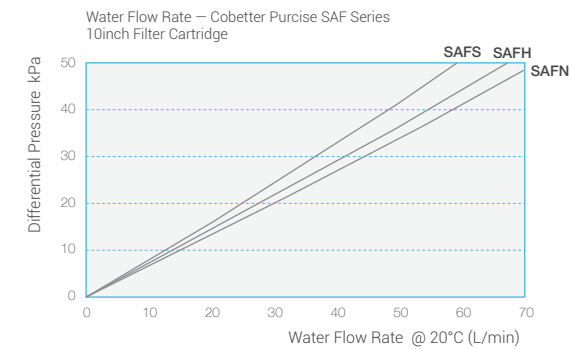
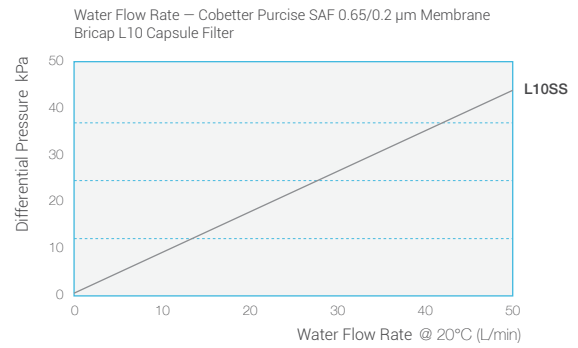
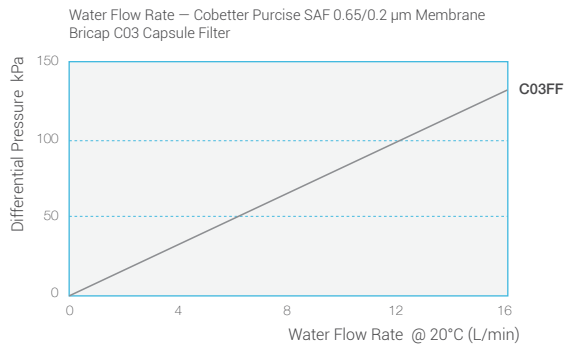
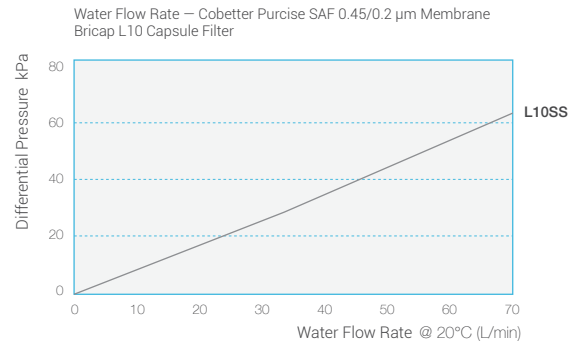
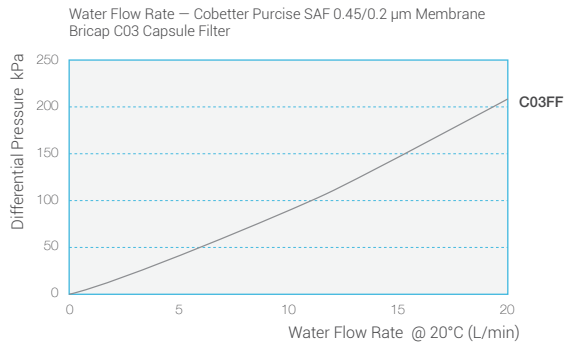
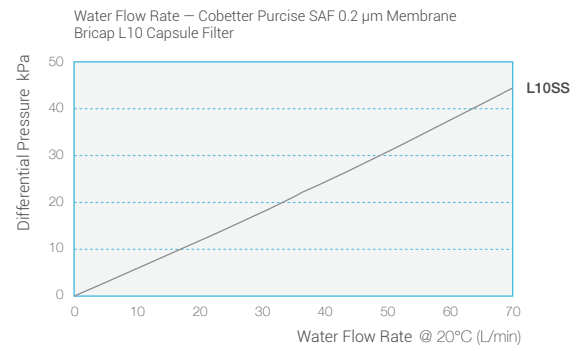
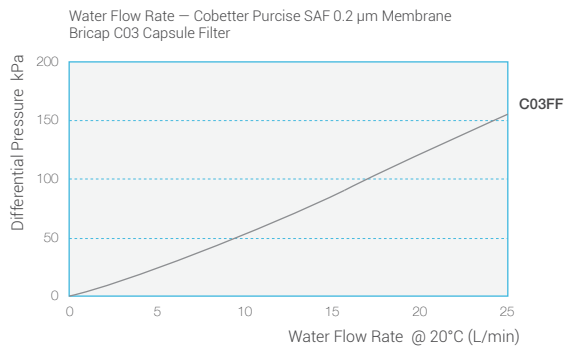

## Regulatory Compliance

- Effluent meets the USP<788> requirement of particulate matter in large volume injection.
- Component materials meet the criteria for a "Non-fiber-releasing filter" as defined in 21 CFR 210.3(b)(6).
- Retention of  $10^7$  cfu/cm<sup>2</sup> Brevundimonas diminuta (ATCC 19146) according to ASTM F838
- Aqueous extraction from a cartridge contains less than 0.25EU/ml as determined by Limulus Amebocyte Lysate (LAL), meeting requirements of USP<85>.
- Components meet the requirement of USP <87> In Vitro Biological Reactivity Test.
- Components meet the criteria of the USP <88> Biological Reactivity Test for Class V-121 °C plastics.
- Components meet the FDA indirect Food Additive requirements cited in 21 CFR 177-182.
- Based on the current information from our suppliers, all components used in the manufacture of this product are animal-free.

Notes: Contact Cobetter for more specification details.

## Sterilizing-Grade Filter Series

# Purcise SLE Filter

## Hydrophilic Sterilizing-Grade Filter with Low Protein Adsorption



Polyethersulfone (PES) material, optimal filter for final filtration

### Features

Low adsorption and low leachables  
Unwetted filter can be steam sterilized directly

### Typical Applications

Sterile filtration of terminal products  
Sterile filtration of biological products, blood and serum products  
Sterile filtration of vaccine products  
Pre-column/ultra-filtration protection  
Filtration of intermediate products/stock solutions

### Quality Control

100% integrity testing in manufacturing  
Each filter is fully traceable with unique serial number  
ISO 9001:2015 manufacturing facility

### Removal Rating and Effective Filtration Area

|                                 | SLEN(0.2 µm)        | SLES(0.45/0.2 µm)   | SLEH(0.65/0.2 µm)   | SLEL(0.8/0.2 µm)    | SLEC(1.2/0.2 µm)    |
|---------------------------------|---------------------|---------------------|---------------------|---------------------|---------------------|
| A - Standard Cartridge (10")    | 0.55 m <sup>2</sup> | 0.55 m <sup>2</sup> | 0.55 m <sup>2</sup> | 0.55 m <sup>2</sup> | 0.55 m <sup>2</sup> |
| H - High Area Cartridge 1 (10") | 0.8 m <sup>2</sup>  | 0.8 m <sup>2</sup>  | 0.8 m <sup>2</sup>  | 0.8 m <sup>2</sup>  | 0.8 m <sup>2</sup>  |
| L - High Area Cartridge 2 (10") | 1.04 m <sup>2</sup> | 1.04 m <sup>2</sup> | 1.04 m <sup>2</sup> | 1.04 m <sup>2</sup> | 1.04 m <sup>2</sup> |

### Materials of Construction

|                           |   |
|---------------------------|---|
| Membrane                  | Hydrophilic polyethersulfone (PES)                              |
| Support                   | Polypropylene (PP)  |
| Core/Cage/End Caps        | Polypropylene (PP)  |
| Cartridge End Cap Inserts | Polybutylene terephthalate (PBT)<br>(Cartridge exclusive)       |
| Cartridge End Cap O-rings | Silicone / EPDM / Fluoroelastomer /<br>PFA encapsulated O-rings |
| Capsule Housing           | Polypropylene (PP)  |
| Capsule Vent O-rings      | Silicone  |
| SP3 Capsule Port Insert   | 316L Stainless Steel  |
| SP3 Capsule Housing       | Polyetherimide (PEI)  |
| SP3 Capsule O-rings       | Silicone  |

### Maximum Differential Pressure

|  |  |
|--|--|
| A - Standard Cartridge/<br>H - High Area Cartridge 1 | Forward: 0.69 MPa @ 25 °C, 0.40 MPa @ 60 °C, 0.24 MPa @ 80 °C<br>Reverse: 0.30 MPa @ 25 °C, 0.10 MPa @ 80 °C |
| L - High Area Cartridge 2                            | Forward: 0.55 MPa @ 25 °C, 0.40 MPa @ 60 °C, 0.24 MPa @ 80 °C<br>Reverse: 0.30 MPa @ 25 °C, 0.10 MPa @ 80 °C |
| Capsule  | Forward: 0.55 MPa @ 25 °C, 0.1 MPa @ 80 °C<br>Reverse: 0.21 MPa @ 25 °C                                      |

### Integrity Test Standards

|  |  |
|--|--|
| Standard - 10inch<br>(0.55m <sup>2</sup> ) | Bubble Point @20 °C ≥ 0.32 MPa, air, wetted with water<br>Air Diffusion @20 °C ≤ 28 ml/min @0.275 MPa, wetted with water |
| Q Series - 10inch<br>(0.55m <sup>2</sup> ) | Bubble Point @20 °C ≥ 0.39 MPa, air, wetted with water<br>Air Diffusion @20 °C ≤ 28 ml/min @0.275 MPa, wetted with water |

### Sterilization

|  |  |
|--|--|
| A - Standard Cartridge/<br>H - High Area Cartridge 1 | Can be steam sterilized for 30 minutes at 135 °C with 50 cycles (< 30 kPa)<br>Can be autoclaved 50 cycles for 30 minutes at 130 °C   |
| L - High Area Cartridge 2                            | Can be steam sterilized for 30 minutes at 135 °C with 30 cycles (< 30 kPa)<br>Can be autoclaved 30 cycles for 30 minutes at 130 °C   |
| Capsule  | Autoclavable capsules only: Can be autoclaved 25 cycles for 30 minutes at 130 °C, (Can not be steam sterilized in-line)<br>Gamma compatible capsules: Can be sterilized by gamma irradiation at 25-45 kGy or can be autoclaved 5 cycles for 60 minutes at 126 °C. (Can not be steamed in-line)<br>Sterile capsule: Can be sterilized by gamma irradiation at 25-45 kGy<br>Cleansteam bag sterile package: Pre-sterilized with autoclave for 30 minutes at 121 °C |

Notes: Gamma sterilized products cannot be re-sterilized with gamma irradiation or steam sterilization

## Flow Rates

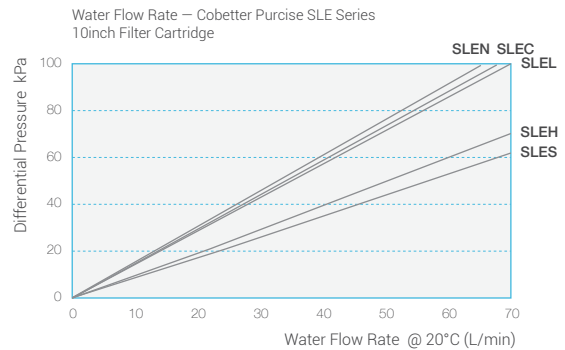
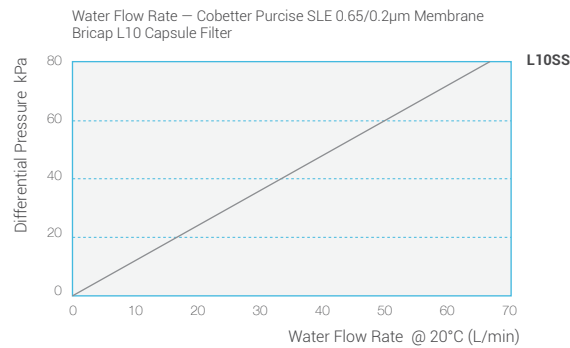
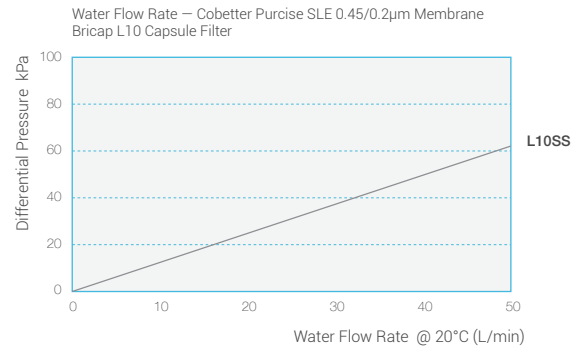
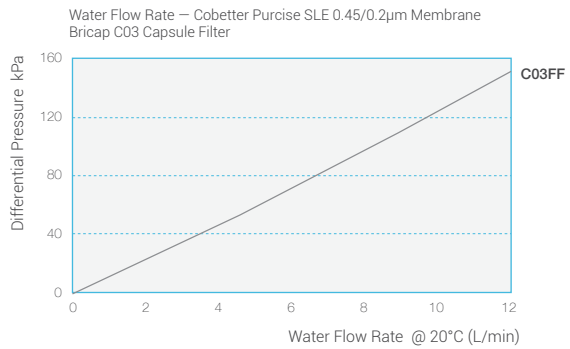
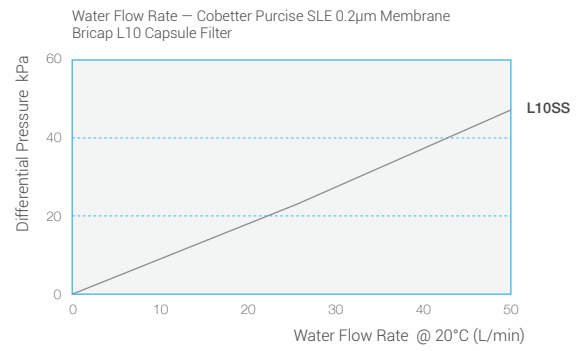
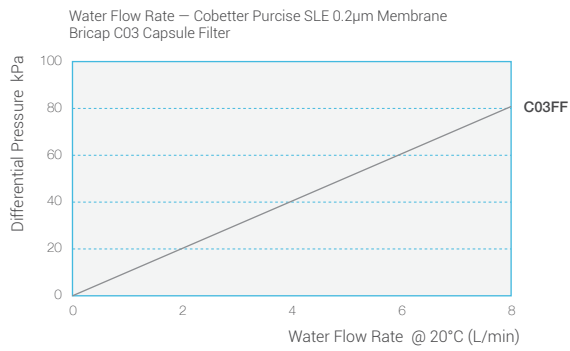

## Regulatory Compliance

- Effluent meets the USP<788> requirement of particulate matter in large volume injection.
- Component materials meet the criteria for a "Non-fiber-releasing filter" as defined in 21 CFR 210.3(b)(6).
- Retention of  $10^7$  cfu/cm<sup>2</sup> Brevundimonas diminuta (ATCC 19146) according to ASTM F838
- Aqueous extraction from a cartridge contains less than 0.25EU/ml as determined by Limulus Amebocyte Lysate (LAL), meeting requirements of USP<85>.
- Components meet the requirement of USP <87> In Vitro Biological Reactivity Test.
- Components meet the criteria of the USP <88> Biological Reactivity Test for Class V-121 °C plastics.
- Components meet the FDA indirect Food Additive requirements cited in 21 CFR 177-182.
- Based on the current information from our suppliers, all components used in the manufacture of this product are animal-free.

Notes: Contact Cobetter for more specification details.

## Purcise SAF/SLE Filter

### Ordering Information

#### Filter Cartridge



Cartridge Format

- A** Standard Cartridge
- H** H - High Area Cartridge(0.69-0.8m<sup>2</sup>)
- L** L - High Area Cartridge(1.0-1.2m<sup>2</sup>)



Membrane Type

- SAFN** SAF 0.2µm
- SAFS** SAF 0.45/0.2µm
- SAFH** SAF 0.65/0.2µm
- SLEN** SLE 0.2µm
- SLES** SLE 0.45/0.2 µm
- SLEH** SLE 0.65/0.2 µm
- SLEL** SLE 0.8/0.2 µm
- SLEC** SLE 1.2/0.2 µm



Length

- 02** 2.5 inch
- 05** 5 inch
- 10** 10 inch
- 20** 20 inch
- 30** 30 inch
- 40** 40 inch



Code

- 0** DOE
- 2** 226 / Flat
- 7** 226 / Fin
- 3** 222 / Flat
- 8** 222 / Fin
- 6** 222 / 3-Flange bayonet / Fin



O-ring Material

- S** Silicone
- E** EPDM
- V** Fluoroelastomer
- P** FEP/PFA encapsulated O-rings



Category

- Blank** Standard
- Q**



Pharmaceutical Grade

#### Bricap C Series Capsule Filter



Housing Type

- Blank** Standard
- K** Transparent



Capsule Format

- C01** BricapC01
- C02** BricapC02
- C03** Bricap C03



Inlet/Outlet

- T** 19 mm (3/4") Sanitary Flange
- K** 14 mm (9/16") Sanitary Flange
- F** 31 mm (1 1/4") Sanitary Flange
- V** 14 mm (9/16") Hose Barb
- H** 13 mm (1/2") Hose Barb
- Y** 9.6 mm (3/8") Hose Barb
- L** 3.2 mm (1/8") Hose Barb
- B** 6-13 mm (1/4"-1/2") Stepped Hose Barb (No Filling Bell)
- A** 6-13 mm (1/4"-1/2") Stepped Hose Barb with Filling Bell (Outlet only)

#### Bricap D Series Capsule Filter



Capsule Format

- D01** BricapD01



Inlet/Outlet

- B** 6-13 mm (1/4"-1/2") Stepped Hose Barb (No Filling Bell)
- A** 6-13 mm (1/4"-1/2") Stepped Hose Barb with Filling Bell (Outlet only)

#### Bricap L Series Capsule Filter



Housing Type

- Blank** Standard
- K** Transparent



Capsule Format

- L02** Bricap L02
- L03** Bricap L03
- L05** Bricap L05
- L10** Bricap L10
- L20** Bricap L20
- L30** Bricap L30



Inlet/Outlet

- S** 38 mm (1 1/2") Sanitary Flange
- T** 19 mm (3/4") Sanitary Flange
- K** 14 mm (9/16") Sanitary Flange
- D** 25 mm (1") Hose Barb
- M** 19 mm (3/4") Hose Barb
- X** 16 mm (5/8") Hose Barb
- V** 14 mm (9/16") Hose Barb
- H** 13 mm (1/2") Hose Barb
- Y** 9.6 mm (3/8") Hose Barb

#### Bricap T Series Capsule Filter



Capsule Format

- T10** Bricap T10
- T20** Bricap T20
- T30** Bricap T30



Inlet/Outlet

- SS** 38 mm (1 1/2") Sanitary Flange Inlet & Outlet
- SM** 38 mm (1 1/2") Sanitary Flange Inlet & 19 mm (3/4") Hose Barb Outlet



Gauge Port Type

- S** 38 mm (1 1/2") Sanitary Flange
- T** 19 mm (3/4") Sanitary Flange
- N** Without Gauge Port

|                             |   |                  |                       |                      |
|-----------------------------|---|------------------|-----------------------|----------------------|
|                             |   |                  |                       |                      |
| Membrane Type               | Sterilization                           | Quantity/Package | Category              | Pharmaceutical Grade |
| <b>SAFN</b> SAF 0.2µm       | <b>A</b> Autoclavable                   | <b>1</b> 1 /pkg  | <b>Blank</b> Standard | Pharmaceutical Grade |
| <b>SAFS</b> SAF 0.45/0.2µm  | <b>G</b> Gamma Compatible               |                  | <b>Q</b>              |                      |
| <b>SAFH</b> SAF 0.65/0.2µm  | <b>S</b> Sterile                        |                  |                       |                      |
| <b>SLEN</b> SLE 0.2µm       | <b>C</b> Cleansteam Bag Sterile Package |                  |                       |                      |
| <b>SLES</b> SLE 0.45/0.2 µm |   |                  |                       |                      |
| <b>SLEH</b> SLE 0.65/0.2 µm |   |                  |                       |                      |
| <b>SLEL</b> SLE 0.8/0.2 µm  |   |                  |                       |                      |
| <b>SLEC</b> SLE 1.2/0.2 µm  |   |                  |                       |                      |



## Bricap HL Series Capsule Filter



Capsule Format

**HL02** Bricap HL02  
**HL03** Bricap HL03  
**HL05** Bricap HL05  
**HL10** Bricap HL10  
**HL20** Bricap HL20  
**HL30** Bricap HL30



Inlet/Outlet

**S** 38 mm (1 1/2") Sanitary Flange  
**T** 19 mm (3/4") Sanitary Flange  
**V** 14 mm (9/16") Hose Barb  
**D** 25 mm (1") Hose Barb  
**H** 13 mm (1/2") Hose Barb  
**Y** 9.6 mm (3/8") Hose Barb

## Bricap HT Series Capsule Filter



Capsule Format

**HT02** Bricap HT02  
**HT03** Bricap HT03  
**HT05** Bricap HT05  
**HT10** Bricap HT10  
**HT20** Bricap HT20  
**HT30** Bricap HT30



Inlet/Outlet

**SS** 38 mm (1 1/2") Sanitary Flange  
**SM** 38 mm (1 1/2") Sanitary Flange Inlet and 19 mm (3/4") Hose Barb Outlet



Gauge Port Type

**S** 38 mm (1 1/2") Sanitary Flange  
**T** 19 mm (3/4") Sanitary Flange  
**N** None



Membrane Type

**HSAFN** HSAF 0.2 µm  
**LSAFN** LSAF 0.2 µm  
**HSAFS** HSAF 0.45/0.2 µm  
**LSAFS** LSAF 0.45/0.2 µm  
**HSAFH** HSAF 0.65/0.2 µm  
**LSAFH** LSAF 0.65/0.2 µm  
**HSLEN** HSLE 0.2 µm  
**LSLEN** LSLE 0.2 µm  
**HSLES** HSLE 0.45/0.2 µm  
**LSLES** LSLE 0.45/0.2 µm  
**HSLEH** HSLE 0.65/0.2 µm  
**LSLEH** LSLE 0.65/0.2 µm  
**HSLEL** HSLE 0.8/0.2 µm  
**LSLEL** LSLE 0.8/0.2 µm  
**HSLEC** HSLE 1.2/0.2 µm  
**LSLEC** LSLE 1.2/0.2 µm



Sterilization

**A** Autoclavable  
**G** Gamma Compatible  
**S** Sterile  
**C** Cleansteam Bag Sterile Package



Quantity/  
Package

**1** 1 /pkg



Category

**Blank** Standard Pharmaceutical Grade  
**Q**



## Brisip SP3 Series Capsule Filter



Capsule Format

**SP3** Brisip SP3



Inlet/Outlet

**S** 38 mm (1 1/2") Sanitary Flange



Membrane Type

**SAFN** SAF 0.2µm  
**SAFS** SAF 0.45/0.2µm  
**SAFH** SAF 0.65/0.2µm  
**SLEN** SLE 0.2µm  
**SLES** SLE 0.45/0.2 µm  
**SLEH** SLE 0.65/0.2 µm  
**SLEL** SLE 0.8/0.2 µm  
**SLEC** SLE 1.2/0.2 µm



Vent and Drain Valves

**P** Both using 6 mm hose barb  
**X** Vent valve using quick coupling (compatible with Stäubli connector), and drain valve using 6 mm hose barb  
**T** Both using quick coupling (compatible with Stäubli connector)  
**V** Both using 13 mm (1/2") sanitary flange



Quantity/  
Package

**1** 1 /pkg



Category

**Blank** Standard Pharmaceutical Grade  
**Q**



## BriScale A50 Liquid Disc Filter



Disc Filter Format

**A50** BriScale A50



Inlet/Outlet

**BB** 6-13 mm (1/4"-1/2") Stepped Hose Barb Inlet and Outlet (No Filling Bell)  
**BA** 6-13 mm (1/4"-1/2") Stepped Hose Barb Inlet and Outlet (Outlet with Filling Bell)

## Bricap SFU Series Syringe Filter (No Vent)



Syringe Filter Format

**U13** Bricap SFU13  
**U25** Bricap SFU25  
**U33** Bricap SFU33



Inlet/Outlet

**CP** Female luer lock inlet and male luer lock outlet

## Bricap SFV Series Syringe Filter (With Luer Vent)



Syringe Filter Format

**V25** Bricap SFV25



Inlet/Outlet

**CP** Female luer lock inlet and male luer lock outlet



Membrane Type

**SAFN** SAF 0.2µm  
**SAFS** SAF 0.45/0.2µm  
**SAFH** SAF 0.65/0.2µm  
**SLEN** SLE 0.2µm  
**SLES** SLE 0.45/0.2 µm  
**SLEH** SLE 0.65/0.2 µm  
**SLEL** SLE 0.8/0.2 µm  
**SLEC** SLE 1.2/0.2 µm



Sterilization

**A** Autoclavable  
**G** Gamma Compatible  
**S** Sterile



Quantity/  
Package

**1** 1 /pkg



Category

**Blank** Standard Pharmaceutical Grade  
**Q**



## Sterilizing-Grade Filter Series

# Purcise SLEB Filter

## Hydrophilic Sterilizing-Grade Filter with Low Protein Adsorption



Sterile filtration products specifically designed for complex fluids.

### Features

Low adsorption and low leachables  
Unwetted filter can be steam sterilized directly

### Typical Applications

Final sterile filtration  
Sterile filtration of complex fluids, liposome  
Sterile filtration of emulsion, high viscous fluids

### Quality Control

100% integrity testing in manufacturing  
Each filter is fully traceable with unique serial number  
ISO 9001:2015 manufacturing facility

### Removal Rating and Effective Filtration Area

|                                 | SLEB(0.2/0.2 μm)    |
|---------------------------------|---------------------|
| A - Standard Cartridge (10")    | 0.55 m <sup>2</sup> |
| H - High Area Cartridge 1 (10") | 0.8 m <sup>2</sup>  |
| L - High Area Cartridge 2 (10") | 1.04 m <sup>2</sup> |

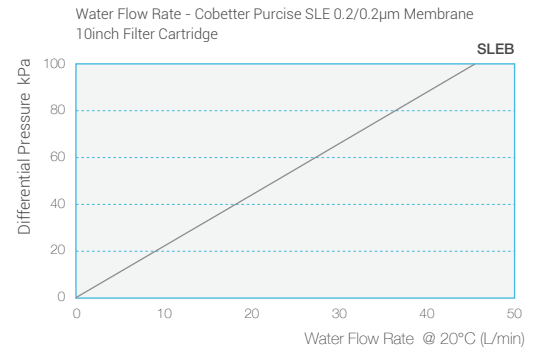

### Materials of Construction

|                           |   |
|---------------------------|---|
| Membrane                  | Hydrophilic polyethersulfone (PES)                              |
| Support                   | Polypropylene (PP)  |
| Core/Cage/End Caps        | Polypropylene (PP)  |
| Cartridge End Cap Inserts | Polybutylene terephthalate (PBT)<br>(Cartridge exclusive)       |
| Cartridge End Cap O-rings | Silicone / EPDM / Fluoroelastomer /<br>PFA encapsulated O-rings |
| Capsule Housing           | Polypropylene (PP)  |
| Capsule Vent O-rings      | Silicone  |
| SP3 Capsule Port Insert   | 316L Stainless Steel  |
| SP3 Capsule Housing       | Polyetherimide (PEI)  |
| SP3 Capsule O-rings       | Silicone  |

### Maximum Differential Pressure

|                           |  |
|---------------------------|--|
| A - Standard Cartridge/   | Forward: 0.69 MPa @ 25 °C, 0.40 MPa @ 60 °C, 0.24 MPa @ 80 °C  |
| H - High Area Cartridge 1 | Reverse: 0.30 MPa @ 25 °C, 0.10 MPa @ 80 °C  |
| L - High Area Cartridge 2 | Forward: 0.55 MPa @ 25 °C, 0.40 MPa @ 60 °C, 0.24 MPa @ 80 °C<br>Reverse: 0.30 MPa @ 25 °C, 0.10 MPa @ 80 °C |
| Capsule                   | Forward: 0.55 MPa @ 25 °C, 0.1 MPa @ 80 °C<br>Reverse: 0.21 MPa @ 25 °C                                      |

### Integrity Test Standards

|  |  |
|--|--|
| Standard - 10inch<br>(0.55m <sup>2</sup> ) | Bubble Point @20 °C ≥ 0.39 MPa, air, wetted with water<br>Air Diffusion @20 °C ≤ 28 ml/min @0.275 MPa, wetted with water |
|--|--|

## Sterilization

|  |  |
|--|--|
| A - Standard Cartridge/<br>H - High Area Cartridge 1 | Can be steam sterilized for 30 minutes at 135 °C with 50 cycles (< 30 kPa)<br>Can be autoclaved 50 cycles for 30 minutes at 130°C  |
| L - High Area Cartridge 2                            | Can be steam sterilized for 30 minutes at 135 °C with 30 cycles (< 30 kPa)<br>Can be autoclaved 30 cycles for 30 minutes at 130°C  |
| Capsule  | Autoclavable capsules only: Can be autoclaved 25 cycles for 30 minutes at 130°C, (Can not be steam sterilized in-line)<br>Gamma compatible capsules: Can be sterilized by gamma irradiation at 25-45 kGy or can be autoclaved 5 cycles for 60 minutes at 126 °C. (Can not be steamed in-line)<br>Sterile capsule: Can be sterilized by gamma irradiation at 25-45 kGy<br>Cleansteam bag sterile package: Pre-sterilized with autoclave for 30 minutes at 121°C |

Notes: Gamma sterilized products cannot be re-sterilized with gamma irradiation or steam sterilization

## Regulatory Compliance

- Effluent meets the USP<788> requirement of particulate matter in large volume injection.
- Component materials meet the criteria for a “Non-fiber-releasing filter” as defined in 21 CFR 210.3(b)(6).
- Retention of  $10^7$  cfu/cm<sup>2</sup> Brevundimonas diminuta (ATCC 19146) according to ASTM F838
- Aqueous extraction from a cartridge contains less than 0.25EU/ml as determined by Limulus Amebocyte Lysate (LAL), meeting requirements of USP<85>.
- Components meet the requirement of USP <87> In Vitro Biological Reactivity Test.
- Components meet the criteria of the USP <88> Biological Reactivity Test for Class V-121 °C plastics.
- Components meet the FDA indirect Food Additive requirements cited in 21 CFR 177-182.
- Based on the current information from our suppliers, all components used in the manufacture of this product are animal-free.

Notes: Contact Cobetter for more specification details.

## Purcise SLEB Filter

### Ordering Information

#### Filter Cartridge



Cartridge Format

- A** Standard Cartridge
- H** H - High Area Cartridge(0.69-0.8m<sup>2</sup>)
- L** L - High Area Cartridge(1.0-1.2m<sup>2</sup>)



Membrane Type

- SLEB** SLE 0.2/0.2µm



Length

- 02** 2.5 inch
- 05** 5 inch
- 10** 10 inch
- 20** 20 inch
- 30** 30 inch
- 40** 40 inch



Code

- 0** DOE
- 2** 226 / Flat
- 7** 226 / Fin
- 3** 222 / Flat
- 8** 222 / Fin
- 6** 222 / 3-Flange bayonet / Fin



O-ring Material

- S** Silicone
- E** EPDM
- V** Fluoroelastomer
- P** FEP/PFA encapsulated O-rings



Pharmaceutical Grade

#### Bricap C Series Capsule Filter



Housing Type

- Blank** Standard
- K** Transparent



Capsule Format

- C01** BricapC01
- C02** BricapC02
- C03** BricapC03



Inlet/Outlet

- T** 19 mm(3/4") Sanitary Flange
- K** 14 mm (9/16") Sanitary Flange
- F** 31 mm (1 1/4") Sanitary Flange
- V** 14 mm (9/16") Hose Barb
- H** 13 mm (1/2") Hose Barb
- Y** 9.6 mm (3/8") Hose Barb
- L** 3.2 mm (1/8") Hose Barb
- B** 6-13 mm (1/4"-1/2") Stepped Hose Barb (No Filling Bell)
- A** 6-13 mm (1/4"-1/2") Stepped Hose Barb with Filling Bell (Outlet only)

#### Bricap D Series Capsule Filter



Capsule Format

- D01** BricapD01



Inlet/Outlet

- B** 6-13 mm (1/4"-1/2") Stepped Hose Barb (No Filling Bell)
- A** 6-13 mm (1/4"-1/2") Stepped Hose Barb with Filling Bell (Outlet only)

#### Bricap L Series Capsule Filter



Housing Type

- Blank** Standard
- K** Transparent



Capsule Format

- L02** Bricap L02
- L03** Bricap L03
- L05** Bricap L05
- L10** Bricap L10
- L20** Bricap L20
- L30** Bricap L30



Inlet/Outlet

- S** 38 mm (1 1/2") Sanitary Flange
- T** 19 mm (3/4") Sanitary Flange
- K** 14 mm (9/16") Sanitary Flange
- D** 25 mm (1") Hose Barb
- M** 19 mm (3/4") Hose Barb
- X** 16 mm (5/8") Hose Barb
- V** 14 mm (9/16") Hose Barb
- H** 13 mm (1/2") Hose Barb
- Y** 9.6 mm (3/8") Hose Barb

#### Bricap T Series Capsule Filter



Capsule Format

- T10** Bricap T10
- T20** Bricap T20
- T30** Bricap T30



Inlet/Outlet

- SS** 38 mm (1 1/2") Sanitary Flange Inlet & Outlet
- SM** 38 mm (1 1/2") Sanitary Flange Inlet & 19 mm (3/4") Hose Barb Outlet



Gauge Port Type

- S** 38 mm (1 1/2") Sanitary Flange
- T** 19 mm (3/4") Sanitary Flange
- N** Without Gauge Port

Membrane Type

- SLEB** SLE 0.2/0.2µm

Sterilization

- A** Autoclavable
- G** Gamma Compatible
- S** Sterile
- C** Cleansteam Bag Sterile Package

Quantity/Package

- 1** 1 /pkg

Pharmaceutical Grade

**cobetter**  
Filtration

Filtration, Separation & Purification  
Solutions for Biopharma

- 19 -



### Bricap HL Series Capsule Filter



Capsule Format

- HL02** Bricap HL02
- HL03** Bricap HL03
- HL05** Bricap HL05
- HL10** Bricap HL10
- HL20** Bricap HL20
- HL30** Bricap HL30



Inlet/Outlet

- S** 38 mm (1 1/2") Sanitary Flange
- T** 19 mm (3/4") Sanitary Flange
- V** 14 mm (9/16") Hose Barb
- D** 25 mm (1") Hose Barb
- H** 13 mm (1/2") Hose Barb
- Y** 9.6 mm (3/8") Hose Barb

### Bricap HT Series Capsule Filter



Capsule Format

- HT02** Bricap HT02
- HT03** Bricap HT03
- HT05** Bricap HT05
- HT10** Bricap HT10
- HT20** Bricap HT20
- HT30** Bricap HT30



Inlet/Outlet

- SS** 38 mm (1 1/2") Sanitary Flange
- SM** 38 mm (1 1/2") Sanitary Flange Inlet and 19 mm (3/4") Hose Barb Outlet



Gauge Port Type

- S** 38 mm (1 1/2") Sanitary Flange
- T** 19 mm (3/4") Sanitary Flange
- N** None

### Brisip SP3 Series Capsule Filter



Capsule Format

- SP3** Brisip SP3



Inlet/Outlet

- S** 38 mm (1 1/2") Sanitary Flange



Membrane Type

- SLEB** SLE 0.2/0.2 µm



Vent and Drain Valves

- P** Both using 6 mm hose barb
- X** Vent valve using quick coupling (compatible with Stäubli connector), and drain valve using 6 mm hose barb
- T** Both using quick coupling (compatible with Stäubli connector)
- V** Both using 13 mm (1/2") sanitary flange



Quantity/Package

- 1** 1 /pkg



Pharmaceutical Grade

### BriScale A50 Liquid Disc Filter



Disc Filter Format

- A50** BriScale A50



Inlet/Outlet

- BB** 6-13 mm (1/4"-1/2") Stepped Hose Barb Inlet and Outlet (No Filling Bell)
- BA** 6-13 mm (1/4"-1/2") Stepped Hose Barb Inlet and Outlet (Outlet with Filling Bell)

### Bricap SFU Series Syringe Filter (No Vent)



Syringe Filter Format

- U13** Bricap SFU13
- U25** Bricap SFU25
- U33** Bricap SFU33



Inlet/Outlet

- CP** Female luer lock inlet and male luer lock outlet

### Bricap SFV Series Syringe Filter (With Luer Vent)



Syringe Filter Format

- V25** Bricap SFV25



Inlet/Outlet

- CP** Female luer lock inlet and male luer lock outlet



Membrane Type

- HSLEB** HSLE 0.2/0.2 µm
- LSLEB** LSLE 0.2/0.2 µm



Sterilization

- A** Autoclavable
- G** Gamma Compatible
- S** Sterile
- C** Cleansteam Bag Sterile Package



Quantity/Package

- 1** 1 /pkg



Pharmaceutical Grade



Membrane Type

- SLEB** SLE 0.2/0.2 µm



Sterilization

- A** Autoclavable
- G** Gamma Compatible
- S** Sterile



Quantity/Package

- 1** 1 /pkg



Pharmaceutical Grade

## Sterilizing-Grade Filter Series

# Purcise SLTS Filter

## Sterilizing-Grade Filter with Low Adsorption



### Features

Low cytotoxicity  
Low adsorption

### Typical Applications

Culture-medium sterile filtration

### Quality Control

100% integrity testing in manufacturing  
Each filter is fully traceable with unique serial number  
ISO 9001:2015 manufacturing facility

### Removal Rating and Effective Filtration Area

|                              | SLTS(0.45/0.2 μm)   | SLTH(0.65/0.2 μm)   | SLTL(0.8/0.2 μm)    |
|------------------------------|---------------------|---------------------|---------------------|
| A - Standard Cartridge (10") | 0.55 m <sup>2</sup> | 0.55 m <sup>2</sup> | 0.55 m <sup>2</sup> |

### Materials of Construction

|                           |   |
|---------------------------|---|
| Membrane                  | Hydrophilic polyethersulfone (PES)                            |
| Support                   | Polypropylene (PP)  |
| Core/Cage/End Caps        | Polypropylene (PP)  |
| Cartridge End Cap Inserts | Polybutylene terephthalate (PBT)<br>(Cartridge exclusive)     |
| Cartridge End Cap O-rings | Silicone /EPDM /Fluoroelastomer /<br>PFA encapsulated O-rings |
| Capsule Housing           | Polypropylene (PP)  |
| Capsule Vent O-rings      | Silicone  |

### Maximum Differential Pressure

|                        |   |
|------------------------|---|
| A - Standard Cartridge | Forward: 0.69 MPa @ 25 °C, 0.40 MPa @ 60 °C, 0.24 MPa @ 80 °C |
|                        | Reverse: 0.30 MPa @ 25 °C, 0.10 MPa @ 80 °C                   |
| Capsule                | Forward: 0.55 MPa @ 25 °C, 0.1 MPa @ 80 °C                    |
|                        | Reverse: 0.21 MPa @ 25 °C                                     |

### Integrity Test Standards

|  |  |
|--|--|
| Standard - 10inch<br>(0.55m <sup>2</sup> ) | Bubble Point @20 °C ≥ 0.34 MPa, air, wetted with water         |
|  | Air Diffusion @20 °C ≤ 28 ml/min @0.275 MPa, wetted with water |

### Sterilization

|                        |   |
|------------------------|---|
| A - Standard Cartridge | Can be steam sterilized for 30 minutes at 135 °C with 50 cycles (< 30 kPa)  |
|                        | Can be autoclaved 50 cycles for 30 minutes at 130°C   |
| Capsule                | Autoclavable capsules only : Can be autoclaved 25 cycles for 30 minutes at 130°C, (Can not be steam sterilized in-line)   |
|                        | Gamma compatible capsules: Can be sterilized by gamma irradiation at 25-45 kGy or can be autoclaved 5 cycles for 60 minutes at 126 °C. (Can not be steamed in-line) |
|                        | Sterile capsule: Can be sterilized by gamma irradiation at 25-45 kGy  |
|                        | Cleansteam bag sterile package: Pre-sterilized with autoclave for 30 minutes at 121°C   |

Notes: Gamma sterilized products cannot be re-sterilized with gamma irradiation or steam sterilization

## Water Flow Rate

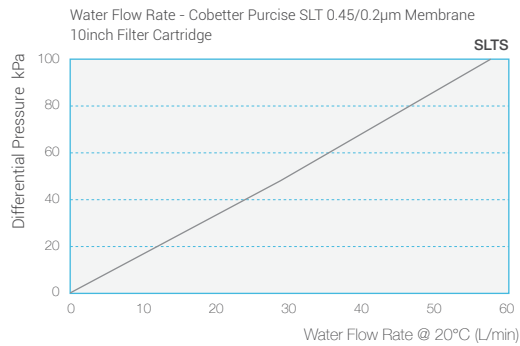

## Regulatory Compliance

- Effluent meets the USP<788> requirement of particulate matter in large volume injection.
- Component materials meet the criteria for a "Non-fiber-releasing filter" as defined in 21 CFR 210.3(b)(6).
- Retention of  $10^7$  cfu/cm<sup>2</sup> *Brevundimonas diminuta* (ATCC 19146) according to ASTM F838
- Aqueous extraction from a cartridge contains less than 0.25EU/ml as determined by Limulus Amebocyte Lysate (LAL), meeting requirements of USP<85>.
- Components meet the requirement of USP <87> In Vitro Biological Reactivity Test.
- Components meet the criteria of the USP <88> Biological Reactivity Test for Class V-121 °C plastics.
- Components meet the FDA indirect Food Additive requirements cited in 21 CFR177-182.
- Based on the current information from our suppliers, all components used in the manufacture of this product are animal-free.

Notes: Contact Cobetter for more specification details.

## Sterilizing-Grade Filter Series

# Purcise SBVS Filter Sterilizing-Grade Filter



High loading, low adsorption

### Typical Applications

Animal vaccine filtration  
Paclitaxel albumin solution filtration

### Quality Control

100% integrity testing in manufacturing  
Each filter is fully traceable with unique serial number  
ISO 9001:2015 manufacturing facility

### Removal Rating and Effective Filtration Area

|                              | SBVS(0.45/0.2 µm)   |
|------------------------------|---------------------|
| A - Standard Cartridge (10") | 0.55 m <sup>2</sup> |

### Maximum Operating Pressure

|                        |  |
|------------------------|--|
| A - Standard Cartridge | 0.69 MPa @ 25 °C, 0.40 MPa @ 60 °C, 0.24 MPa @ 80 °C |
| Capsule                | 0.55 MPa @ 25 °C, 0.10 MPa @ 80 °C                   |

### Materials of Construction

|                           |   |
|---------------------------|---|
| Membrane                  | Hydrophilic polyethersulfone (PES)                              |
| Support                   | Polypropylene (PP)  |
| Core/Cage/End Caps        | Polypropylene (PP)  |
| Cartridge End Cap Inserts | Polybutylene terephthalate (PBT)<br>(Cartridge exclusive)       |
| Cartridge End Cap O-rings | Silicone / EPDM / Fluoroelastomer /<br>PFA encapsulated O-rings |
| Capsule Housing           | Polypropylene (PP)  |
| Capsule Vent O-rings      | Silicone  |
| SP3 Capsule Port Insert   | 316L Stainless Steel  |
| SP3 Capsule Housing       | Polyetherimide (PEI)  |
| SP3 Capsule O-rings       | Silicone  |

### Maximum Differential Pressure

|                    |   |
|--------------------|---|
| Standard Cartridge | Forward: 0.69 MPa @ 25 °C, 0.40 MPa @ 60 °C, 0.24 MPa @ 80 °C |
|                    | Reverse: 0.30 MPa @ 25 °C, 0.10 MPa @ 80 °C                   |
| Capsule            | Forward: 0.55 MPa @ 25 °C, 0.1 MPa @ 80 °C                    |
|                    | Reverse: 0.21 MPa @ 25 °C                                     |

### Integrity Test Standards

|  |  |
|--|--|
| Standard - 10inch<br>(0.55m <sup>2</sup> ) | Bubble Point @20 °C ≥ 0.39 MPa, air, wetted with water         |
|  | Air Diffusion @20 °C ≤ 28 ml/min @0.275 MPa, wetted with water |

### Sterilization

|                        |   |
|------------------------|---|
| A - Standard Cartridge | Can be steam sterilized for 30 minutes at 135 °C with 50 cycles (< 30 kPa)  |
|                        | Can be autoclaved 50 cycles for 30 minutes at 130 °C  |
| Capsule                | Autoclavable capsules only : Can be autoclaved 25 cycles for 30 minutes at 130 °C, (Can not be steam sterilized in-line)  |
|                        | Gamma compatible capsules: Can be sterilized by gamma irradiation at 25-45 kGy or can be autoclaved 5 cycles for 60 minutes at 126 °C. (Can not be steamed in-line) |
|                        | Sterile capsule: Can be sterilized by gamma irradiation at 25-45 kGy  |
|                        | Cleansteam bag sterile package: Pre-sterilized with autoclave for 30 minutes at 121 °C  |

Notes: Gamma sterilized products cannot be re-sterilized with gamma irradiation or steam sterilization



## Flow Rates

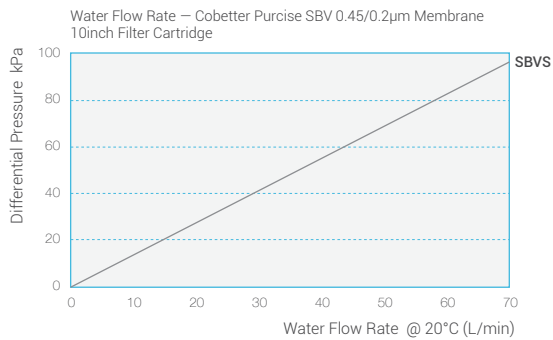

## Regulatory Compliance

- Effluent meets the USP<788> requirement of particulate matter in large volume injection.
- Component materials meet the criteria for a "Non-fiber-releasing filter" as defined in 21 CFR 210.3(b)(6).
- Retention of  $10^7$  cfu/cm<sup>2</sup> *Brevundimonas diminuta* (ATCC 19146) according to ASTM F838
- Aqueous extraction from a cartridge contains less than 0.25EU/ml as determined by Limulus Amebocyte Lysate (LAL), meeting requirements of USP<85>.
- Components meet the requirement of USP <87> In Vitro Biological Reactivity Test.
- Components meet the criteria of the USP <88> Biological Reactivity Test for Class V-121 °C plastics.
- Components meet the FDA indirect Food Additive requirements cited in 21 CFR177-182.
- Based on the current information from our suppliers, all components used in the manufacture of this product are animal-free.

Notes: Contact Cobetter for more specification details.

## Purcise SLTS/SBVS Filter

### Ordering Information

#### Filter Cartridge



Cartridge Format

**A** Standard Cartridge



Membrane Type

**SLTS** SLT 0.45/0.2 µm  
**SLTH** SLT 0.65/0.2 µm  
**SLTL** SLT 0.8/0.2 µm  
**SBVS** SBV 0.45/0.2 µm



Length

**02** 2.5 inch  
**05** 5 inch  
**10** 10 inch  
**20** 20 inch  
**30** 30 inch  
**40** 40 inch



Code

**0** DOE  
**2** 226 / Flat  
**7** 226 / Fin  
**3** 222 / Flat  
**8** 222 / Fin  
**6** 222 / 3-Flange bayonet / Fin



O-ring Material

**S** Silicone  
**E** EPDM  
**V** Fluoroelastomer  
**P** FEP/PFA encapsulated O-rings



Pharmaceutical Grade

#### Bricap C Series Capsule Filter



Capsule Format

**C01** Bricap C01  
**C02** Bricap C02  
**C03** Bricap C03



Inlet/Outlet

**T** 19 mm (3/4") Sanitary Flange  
**K** 14 mm (9/16") Sanitary Flange  
**F** 31 mm (1 1/4") Sanitary Flange  
**V** 14 mm (9/16") Hose Barb  
**H** 13 mm (1/2") Hose Barb  
**Y** 9.6 mm (3/8") Hose Barb  
**L** 3.2 mm (1/8") Hose Barb  
**B** 6-13 mm (1/4"-1/2") Stepped Hose Barb (No Filling Bell)  
**A** 6-13 mm (1/4"-1/2") Stepped Hose Barb with Filling Bell (Outlet only)



Membrane Type

**SLTS** SLT 0.45/0.2 µm  
**SLTH** SLT 0.65/0.2 µm  
**SLTL** SLT 0.8/0.2 µm  
**SBVS** SBV 0.45/0.2 µm



Sterilization

**A** Autoclavable  
**G** Gamma Compatible  
**S** Sterile  
**C** Cleansteam Bag Sterile Package



Quantity/Package

**1** 1 /pkg



Pharmaceutical Grade

#### Bricap D Series Capsule Filter



Capsule Format

**D01** Bricap D01



Inlet/Outlet

**B** 6-13 mm (1/4"-1/2") Stepped Hose Barb (No Filling Bell)  
**A** 6-13 mm (1/4"-1/2") Stepped Hose Barb with Filling Bell (Outlet only)

#### Bricap L Series Capsule Filter



Capsule Format

**L02** Bricap L02  
**L03** Bricap L03  
**L05** Bricap L05  
**L10** Bricap L10  
**L20** Bricap L20  
**L30** Bricap L30



Inlet/Outlet

**S** 38 mm (1 1/2") Sanitary Flange  
**T** 19 mm (3/4") Sanitary Flange  
**K** 14 mm (9/16") Sanitary Flange  
**D** 25 mm (1") Hose Barb  
**M** 19 mm (3/4") Hose Barb  
**X** 16 mm (5/8") Hose Barb  
**V** 14 mm (9/16") Hose Barb  
**H** 13 mm (1/2") Hose Barb  
**Y** 9.6 mm (3/8") Hose Barb

#### Bricap T Series Capsule Filter



Capsule Format

**T10** Bricap T10  
**T20** Bricap T20  
**T30** Bricap T30



Inlet/Outlet







**SS** 38 mm (1 1/2") Sanitary Flange Inlet & Outlet  
**SM** 38 mm (1 1/2") Sanitary Flange Inlet & 19 mm (3/4") Hose Barb Outlet









Gauge Port Type

**S** 38 mm (1 1/2") Sanitary Flange  
**T** 19 mm (3/4") Sanitary Flange  
**N** Without Gauge Port



### Brisip SP3 Series Capsule Filter

|  |   |   |  |   |   |
|--|---|---|--|---|---|
|  |  |                                        |   |  |  |
| Capsule Format   | Inlet/Outlet  | Membrane Type   | Vent and Drain Valves  | Quantity/Package  | Pharmaceutical Grade  |
| <b>SP3</b> Brisip SP3  | <b>S</b> 38 mm (1 1/2") Sanitary Flange   | <b>SLTS</b> SLT 0.45/0.2 µm<br><b>SLTH</b> SLT 0.65/0.2 µm<br><b>SLTL</b> SLT 0.8/0.2 µm<br><b>SBVS</b> SBV 0.45/0.2 µm | <b>P</b> Both using 6 mm hose barb<br><b>X</b> Vent valve using quick coupling (compatible with Stäubli connector), and drain valve using 6 mm hose barb<br><b>T</b> Both using quick coupling (compatible with Stäubli connector)<br><b>V</b> Both using 13 mm (1/2") sanitary flange | <b>1</b> 1 /pkg   |   |



### BriScale A50 Liquid Disc Filter

|  |   |   |   |   |   |
|--|---|---|---|---|---|
|  |    |                                        |  |  |  |
| Disc Filter Format   | Inlet/Outlet  | Membrane Type   | Sterilization   | Quantity/Package  | Pharmaceutical Grade  |
| <b>A50</b> BriScale A50  | <b>BB</b> 6-13 mm (1/4"-1/2") Stepped Hose Barb Inlet and Outlet (No Filling Bell)<br><b>BA</b> 6-13 mm (1/4"-1/2") Stepped Hose Barb Inlet and Outlet (Outlet with Filling Bell) | <b>SLTS</b> SLT 0.45/0.2 µm<br><b>SLTH</b> SLT 0.65/0.2 µm<br><b>SLTL</b> SLT 0.8/0.2 µm<br><b>SBVS</b> SBV 0.45/0.2 µm | <b>A</b> Autoclavable<br><b>G</b> Gamma Compatible<br><b>S</b> Sterile            | <b>1</b> 1 /pkg   |   |

### Bricap SFU Series Syringe Filter (No Vent)

|  |   |
|--|---|
|  |  |
| Syringe Filter Format  | Inlet/Outlet  |
| <b>U13</b> Bricap SFU13<br><b>U25</b> Bricap SFU25<br><b>U33</b> Bricap SFU33    | <b>CP</b> Female luer lock inlet and male luer lock outlet                        |

### Bricap SFV Series Syringe Filter (With Luer Vent)

|  |   |
|--|---|
|  |  |
| Syringe Filter Format  | Inlet/Outlet  |
| <b>V25</b> Bricap SFV25  | <b>CP</b> Female luer lock inlet and male luer lock outlet                          |

## Sterilizing-Grade Filter Series

# Purcise SEAS Filter Sterilizing-Grade Filter



Sterile filtration specially developed for complex fluids

### Features

High loading

### Typical Applications

Intermediate product filtration

### Quality Control

100% integrity testing in manufacturing

Each filter is fully traceable with unique serial number

ISO 9001:2015 manufacturing facility

### Removal Rating and Effective Filtration Area

|                              | SEAS(0.45/0.2 μm)   |
|------------------------------|---------------------|
| A - Standard Cartridge (10") | 0.55 m <sup>2</sup> |

### Materials of Construction

|                           |   |
|---------------------------|---|
| Membrane                  | Hydrophilic polyethersulfone (PES)                              |
| Support                   | Polypropylene (PP)  |
| Core/Cage/End Caps        | Polypropylene (PP)  |
| Cartridge End Cap Inserts | Polybutylene terephthalate (PBT)<br>(Cartridge exclusive)       |
| Cartridge End Cap O-rings | Silicone / EPDM / Fluoroelastomer /<br>PFA encapsulated O-rings |
| Capsule Housing           | Polypropylene (PP)  |
| Capsule Vent O-rings      | Silicone  |
| SP3 Capsule Port Insert   | 316L Stainless Steel  |
| SP3 Capsule Housing       | Polyetherimide (PEI)  |
| SP3 Capsule O-rings       | Silicone  |

### Maximum Differential Pressure

|                        |   |
|------------------------|---|
| A - Standard Cartridge | Forward: 0.69 MPa @ 25 °C, 0.40 MPa @ 60 °C, 0.24 MPa @ 80 °C |
|                        | Reverse: 0.30 MPa @ 25 °C, 0.10 MPa @ 80 °C                   |
| Capsule                | Forward: 0.55 MPa @ 25 °C, 0.1 MPa @ 80 °C                    |
|                        | Reverse: 0.21 MPa @ 25 °C                                     |

### Integrity Test Standards

|  |  |
|--|--|
| Standard - 10inch<br>(0.55m <sup>2</sup> ) | Bubble Point @20 °C ≥ 0.375 MPa, air, wetted with water        |
|  | Air Diffusion @20 °C ≤ 28 ml/min @0.275 MPa, wetted with water |

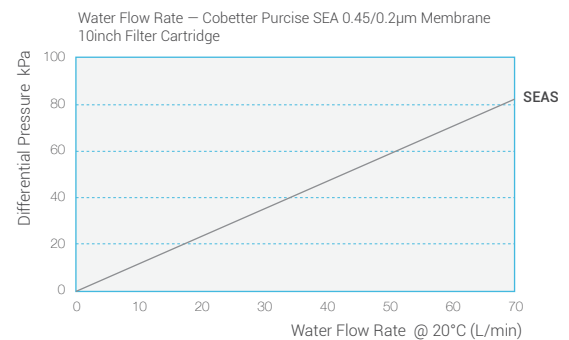

### Sterilization

|                        |   |
|------------------------|---|
| A - Standard Cartridge | Can be steam sterilized for 30 minutes at 135 °C with 50 cycles (< 30 kPa)  |
|                        | Can be autoclaved 50 cycles for 30 minutes at 130°C   |
| Capsule                | Autoclavable capsules only : Can be autoclaved 25 cycles for 30 minutes at 130°C, (Can not be steam sterilized in-line)   |
|                        | Gamma compatible capsules: Can be sterilized by gamma irradiation at 25-45 kGy or can be autoclaved 5 cycles for 60 minutes at 126 °C. (Can not be steamed in-line) |
|                        | Sterile capsule: Can be sterilized by gamma irradiation at 25-45 kGy  |
|                        | Cleansteam bag sterile package: Pre-sterilized with autoclave for 30 minutes at 121 °C  |

Notes: Gamma sterilized products cannot be re-sterilized with gamma irradiation or steam sterilization

### Regulatory Compliance

- Effluent meets the USP<788> requirement of particulate matter in large volume injection.
- Component materials meet the criteria for a "Non-fiber-releasing filter" as defined in 21 CFR 210.3(b)(6).
- Retention of 10<sup>7</sup> cfu/cm<sup>2</sup> Brevundimonas diminuta (ATCC 19146) according to ASTM F838
- Aqueous extraction from a cartridge contains less than 0.25EU/ml as determined by Limulus Amebocyte Lysate (LAL), meeting requirements of USP<85>.
- Components meet the requirement of USP <87> In Vitro Biological Reactivity Test.
- Components meet the criteria of the USP <88> Biological Reactivity Test for Class V-121 °C plastics.
- Components meet the FDA indirect Food Additive requirements cited in 21 CFR177-182.
- Based on the current information from our suppliers, all components used in the manufacture of this product are animal-free.

Notes: Contact Cobetter for more specification details.

## Purcise SEAS Filter

### Ordering Information

#### Filter Cartridge



Cartridge Format

**A** Standard Cartridge



Membrane Type

**SEAS** SEA 0.45/0.2 µm



Length

**02** 2.5 inch  
**05** 5 inch  
**10** 10 inch  
**20** 20 inch  
**30** 30 inch  
**40** 40 inch



Code

**0** DOE  
**2** 226 / Flat  
**7** 226 / Fin  
**3** 222 / Flat  
**8** 222 / Fin  
**6** 222 / 3-Flange bayonet / Fin



O-ring Material

**S** Silicone  
**E** EPDM  
**V** Fluoroelastomer  
**P** FEP/PFA encapsulated O-rings



Pharmaceutical Grade

#### Bricap C Series Capsule Filter



Housing Type

**Blank** Standard  
**K** Transparent



Capsule Format

**C01** Bricap C01  
**C02** Bricap C02  
**C03** Bricap C03



Inlet/Outlet

**T** 19 mm (3/4") Sanitary Flange  
**K** 14 mm (9/16") Sanitary Flange  
**F** 31 mm (1 1/4") Sanitary Flange  
**V** 14 mm (9/16") Hose Barb  
**H** 13 mm (1/2") Hose Barb  
**Y** 9.6 mm (3/8") Hose Barb  
**L** 3.2 mm (1/8") Hose Barb  
**B** 6-13 mm (1/4"-1/2") Stepped Hose Barb (No Filling Bell)  
**A** 6-13 mm (1/4"-1/2") Stepped Hose Barb with Filling Bell (Outlet only)

#### Bricap L Series Capsule Filter



Housing Type

**Blank** Standard  
**K** Transparent



Capsule Format

**L02** Bricap L02  
**L03** Bricap L03  
**L05** Bricap L05  
**L10** Bricap L10  
**L20** Bricap L20  
**L30** Bricap L30



Inlet/Outlet

**S** 38 mm (1 1/2") Sanitary Flange  
**T** 19 mm (3/4") Sanitary Flange  
**K** 14 mm (9/16") Sanitary Flange  
**D** 25 mm (1") Hose Barb  
**M** 19 mm (3/4") Hose Barb  
**X** 16 mm (5/8") Hose Barb  
**V** 14 mm (9/16") Hose Barb  
**H** 13 mm (1/2") Hose Barb  
**Y** 9.6 mm (3/8") Hose Barb

#### Bricap T Series Capsule Filter



Capsule Format

**T10** Bricap T10  
**T20** Bricap T20  
**T30** Bricap T30



Inlet/Outlet

**SS** 38 mm (1 1/2") Sanitary Flange Inlet & Outlet  
**SM** 38 mm (1 1/2") Sanitary Flange Inlet & 19 mm (3/4") Hose Barb Outlet



Gauge Port Type

**S** 38 mm (1 1/2") Sanitary Flange  
**T** 19 mm (3/4") Sanitary Flange  
**N** Without Gauge Port

|                             |   |                  |                      |
|-----------------------------|---|------------------|----------------------|
|                             |   |                  |                      |
| Membrane Type               | Sterilization   | Quantity/Package | Pharmaceutical Grade |
| <b>SEAS</b> SEA 0.45/0.2 µm | <b>A</b> Autoclavable<br><b>G</b> Gamma Compatible<br><b>S</b> Sterile<br><b>C</b> Cleansteam Bag Sterile Package | <b>1</b> 1 /pkg  | Pharmaceutical Grade |



## Mycoplasma Removal Filter Series

# Purcise MLE Filter

## Hydrophilic Filter with High Mycoplasma Retention Rate



### Features

Double-layer design  
 Reliable retention of mycoplasma, bacteria and particles  
 Extensive chemical compatibility  
 Low leachables

### Typical Applications

Typical mycoplasma removal applications  
 Removal of mycoplasma in buffer solution  
 Filtration of intermediate products/ stock solutions  
 Sterile filtration of terminal products

### Quality Control

100% integrity testing in manufacturing  
 Each filter is fully traceable with unique serial number  
 ISO 9001:2015 manufacturing facility

### Removal Rating and Effective Filtration Area

|                                 | MLEB(0.2/0.1 µm)    | MLES(0.45/0.1 µm)   |
|---------------------------------|---------------------|---------------------|
| A - Standard Cartridge (10")    | 0.55 m <sup>2</sup> | 0.55 m <sup>2</sup> |
| H - High Area Cartridge 1 (10") | 0.8 m <sup>2</sup>  | 0.8 m <sup>2</sup>  |
| L - High Area Cartridge 2 (10") | 1.04 m <sup>2</sup> | 1.04 m <sup>2</sup> |

### Materials of Construction

|                           |   |
|---------------------------|---|
| Membrane                  | Hydrophilic polyethersulfone (PES)                              |
| Support                   | Polypropylene (PP)  |
| Core/Cage/End Caps        | Polypropylene (PP)  |
| Cartridge End Cap Inserts | Polybutylene terephthalate (PBT)<br>(Cartridge exclusive)       |
| Cartridge End Cap O-rings | Silicone / EPDM / Fluoroelastomer /<br>PFA encapsulated O-rings |
| Capsule Housing           | Polypropylene (PP)  |
| Capsule Vent O-rings      | Silicone  |
| SP3 Capsule Port Insert   | 316L Stainless Steel  |
| SP3 Capsule Housing       | Polyetherimide (PEI)  |
| SP3 Capsule O-rings       | Silicone  |

### Maximum Differential Pressure

|                           |  |
|---------------------------|--|
| A - Standard Cartridge/   | Forward: 0.69 MPa @ 25 °C, 0.40 MPa @ 60 °C, 0.24 MPa @ 80 °C  |
| H - High Area Cartridge 1 | Reverse: 0.30 MPa @ 25 °C, 0.10 MPa @ 80 °C  |
| L - High Area Cartridge 2 | Forward: 0.55 MPa @ 25 °C, 0.40 MPa @ 60 °C, 0.24 MPa @ 80 °C<br>Reverse: 0.30 MPa @ 25 °C, 0.10 MPa @ 80 °C |
| Capsule                   | Forward: 0.55 MPa @ 25 °C, 0.1 MPa @ 80 °C<br>Reverse: 0.21 MPa @ 25 °C                                      |

### Integrity Test Standards

|   |   |
|---|---|
| Standard - 10inch (0.55m <sup>2</sup> ) | Bubble Point @20 °C ≥ 0.25 MPa, 60% IPA 40% air, wetted with water<br>Air Diffusion @20 °C ≤ 30 ml/min @0.35 MPa, wetted with water |
|---|---|

### Sterilization

|  |  |
|--|--|
| A - Standard Cartridge/<br>H - High Area Cartridge 1 | Can be steam sterilized for 30 minutes at 135 °C with 50 cycles (< 30 kPa)<br>Can be autoclaved 50 cycles for 30 minutes at 130 °C   |
| L - High Area Cartridge 2                            | Can be steam sterilized for 30 minutes at 135 °C with 30 cycles (< 30 kPa)<br>Can be autoclaved 30 cycles for 30 minutes at 130 °C   |
| Capsule  | Autoclavable capsules only: Can be autoclaved 25 cycles for 30 minutes at 130 °C, (Can not be steam sterilized in-line)<br>Gamma compatible capsules: Can be sterilized by gamma irradiation at 25-45 kGy or can be autoclaved 5 cycles for 60 minutes at 126 °C. (Can not be steamed in-line)<br>Sterile capsule: Can be sterilized by gamma irradiation at 25-45 kGy<br>Cleansteam bag sterile package: Pre-sterilized with autoclave for 30 minutes at 121 °C |

Notes: Gamma sterilized products cannot be re-sterilized with gamma irradiation or steam sterilization

## Flow Rates

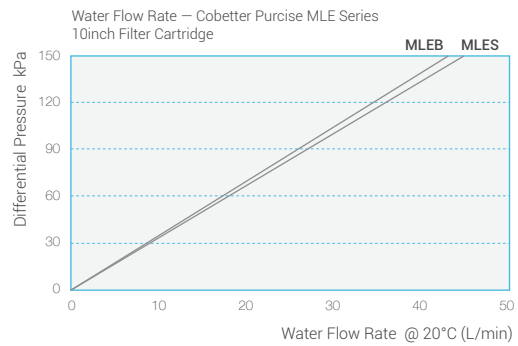
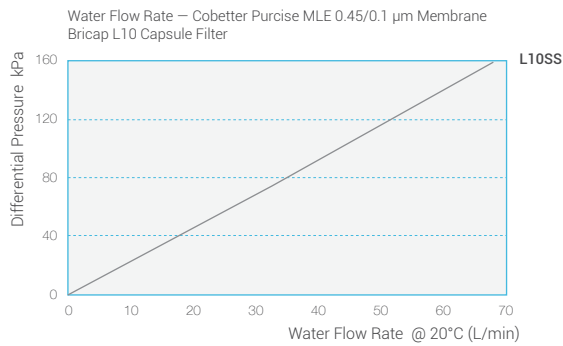
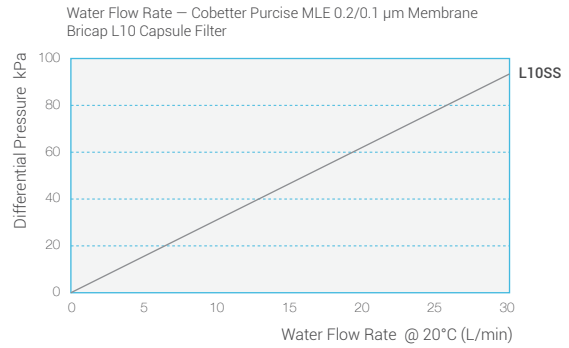
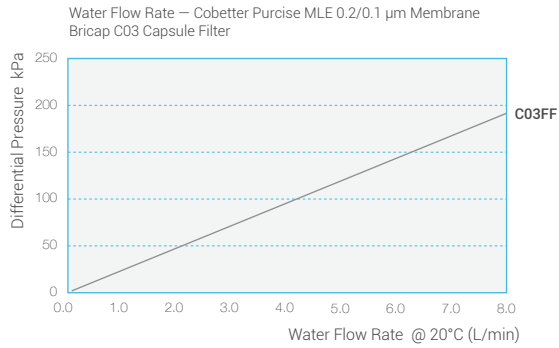

## Regulatory Compliance

- Effluent meets the USP<788> requirement of particulate matter in large volume injection.
- Component materials meet the criteria for a "Non-fiber-releasing filter" as defined in 21 CFR 210.3(b)(6).
- Retention of  $10^7$  cfu/cm<sup>2</sup> *Brevundimonas diminuta* (ATCC 19146) according to ASTM F838
- Aqueous extraction from a cartridge contains less than 0.25EU/ml as determined by Limulus Amebocyte Lysate (LAL), meeting requirements of USP<85>.
- Components meet the requirement of USP <87> In Vitro Biological Reactivity Test.
- Components meet the criteria of the USP <88> Biological Reactivity Test for Class V-121 °C plastics.
- Components meet the FDA indirect Food Additive requirements cited in 21 CFR177-182.
- Based on the current information from our suppliers, all components used in the manufacture of this product are animal-free.

Notes: Contact Cobetter for more specification details.

## Purcise MLE Filter

### Ordering Information

#### Filter Cartridge



Cartridge Format

- A** Standard Cartridge
- H** H - High Area Cartridge(0.69-0.8m<sup>2</sup>)
- L** L - High Area Cartridge(1.0-1.2m<sup>2</sup>)



Membrane Type

- MLEB** MLE 0.2/0.1 μm
- MLES** MLE 0.45/0.1 μm



Length

- 02** 2.5 inch
- 05** 5 inch
- 10** 10 inch
- 20** 20 inch
- 30** 30 inch
- 40** 40 inch



Code

- 0** DOE
- 2** 226 / Flat
- 7** 226 / Fin
- 3** 222 / Flat
- 8** 222 / Fin
- 6** 222 / 3-Flange bayonet / Fin



O-ring Material

- S** Silicone
- E** EPDM
- V** Fluoroelastomer
- P** FEP/PFA encapsulated O-rings



Pharmaceutical Grade

#### Bricap C Series Capsule Filter



Housing Type

- Blank** Standard
- K** Transparent



Capsule Format

- C01** BricapC01
- C02** BricapC02
- C03** BricapC03



Inlet/Outlet

- T** 19 mm(3/4") Sanitary Flange
- K** 14 mm (9/16") Sanitary Flange
- F** 31 mm (1 1/4") Sanitary Flange
- V** 14 mm (9/16") Hose Barb
- H** 13 mm (1/2") Hose Barb
- Y** 9.6 mm (3/8") Hose Barb
- L** 3.2 mm (1/8") Hose Barb
- B** 6-13 mm (1/4"-1/2") Stepped Hose Barb (No Filling Bell)
- A** 6-13 mm (1/4"-1/2") Stepped Hose Barb with Filling Bell (Outlet only)

#### Bricap D Series Capsule Filter



Capsule Format

- D01** BricapD01



Inlet/Outlet

- B** 6-13 mm (1/4"-1/2") Stepped Hose Barb (No Filling Bell)
- A** 6-13 mm (1/4"-1/2") Stepped Hose Barb with Filling Bell (Outlet only)

#### Bricap L Series Capsule Filter



Housing Type

- Blank** Standard
- K** Transparent



Capsule Format

- L02** Bricap L02
- L03** Bricap L03
- L05** Bricap L05
- L10** Bricap L10
- L20** Bricap L20
- L30** Bricap L30



Inlet/Outlet

- S** 38 mm (1 1/2") Sanitary Flange
- T** 19 mm (3/4") Sanitary Flange
- K** 14 mm (9/16") Sanitary Flange
- D** 25 mm (1") Hose Barb
- M** 19 mm (3/4") Hose Barb
- X** 16 mm (5/8") Hose Barb
- V** 14 mm (9/16") Hose Barb
- H** 13 mm (1/2") Hose Barb
- Y** 9.6 mm (3/8") Hose Barb

#### Bricap T Series Capsule Filter



Capsule Format

- T10** Bricap T10
- T20** Bricap T20
- T30** Bricap T30



Inlet/Outlet

- SS** 38 mm (1 1/2") Sanitary Flange Inlet & Outlet
- SM** 38 mm (1 1/2") Sanitary Flange Inlet & 19 mm (3/4") Hose Barb Outlet



Gauge Port Type

- S** 38 mm (1 1/2") Sanitary Flange
- T** 19 mm (3/4") Sanitary Flange
- N** Without Gauge Port

Membrane Type

- MLEB** MLE 0.2/0.1 μm
- MLES** MLE 0.45/0.1 μm

Sterilization

- A** Autoclavable
- G** Gamma Compatible
- S** Sterile
- C** Cleansteam Bag Sterile Package

Quantity/Package

- 1** 1 /pkg

Pharmaceutical Grade

### Bricap HL Series Capsule Filter



Capsule Format

- HL02** Bricap HL02
- HL03** Bricap HL03
- HL05** Bricap HL05
- HL10** Bricap HL10
- HL20** Bricap HL20
- HL30** Bricap HL30



Inlet/Outlet

- S** 38 mm (1 1/2") Sanitary Flange
- T** 19 mm (3/4") Sanitary Flange
- V** 14 mm (9/16") Hose Barb
- D** 25 mm (1") Hose Barb
- H** 13 mm (1/2") Hose Barb
- Y** 9.6 mm (3/8") Hose Barb

### Bricap HT Series Capsule Filter



Capsule Format

- HT02** Bricap HT02
- HT03** Bricap HT03
- HT05** Bricap HT05
- HT10** Bricap HT10
- HT20** Bricap HT20
- HT30** Bricap HT30



Inlet/Outlet

- SS** 38 mm (1 1/2") Sanitary Flange
- SM** 38 mm (1 1/2") Sanitary Flange Inlet and 19 mm (3/4") Hose Barb Outlet



Gauge Port Type

- S** 38 mm (1 1/2") Sanitary Flange
- T** 19 mm (3/4") Sanitary Flange
- N** None

### Brisip SP3 Series Capsule Filter



Capsule Format

- SP3** Brisip SP3



Inlet/Outlet

- S** 38 mm (1 1/2") Sanitary Flange



Membrane Type

- MLEB** MLE 0.2/0.1 µm
- MLES** MLE 0.45/0.1 µm



Vent and Drain Valves

- P** Both using 6 mm hose barb
- X** Vent valve using quick coupling (compatible with Stäubli connector), and drain valve using 6 mm hose barb
- T** Both using quick coupling (compatible with Stäubli connector)
- V** Both using 13 mm (1/2") sanitary flange



Quantity/Package

- 1** 1 /pkg



Pharmaceutical Grade

### BriScale A50 Liquid Disc Filter



Disc Filter Format

- A50** BriScale A50



Inlet/Outlet

- BB** 6-13 mm (1/4"-1/2") Stepped Hose Barb Inlet and Outlet (No Filling Bell)
- BA** 6-13 mm (1/4"-1/2") Stepped Hose Barb Inlet and Outlet (Outlet with Filling Bell)

### Bricap SFU Series Syringe Filter (No Vent)



Syringe Filter Format

- U13** Bricap SFU13
- U25** Bricap SFU25
- U33** Bricap SFU33



Inlet/Outlet

- CP** Female luer lock inlet and male luer lock outlet

### Bricap SFV Series Syringe Filter (With Luer Vent)



Syringe Filter Format

- V25** Bricap SFV25



Inlet/Outlet

- CP** Female luer lock inlet and male luer lock outlet



Membrane Type

- HMLEB** HMLE 0.2/0.1 µm
- LMLEB** LMLE 0.2/0.1 µm
- HMLES** HMLE 0.45/0.1 µm
- LMLES** LMLE 0.45/0.1 µm



Sterilization

- A** Autoclavable
- G** Gamma Compatible
- S** Sterile
- C** Cleansteam Bag Sterile Package



Quantity/Package

- 1** 1 /pkg



Pharmaceutical Grade



Membrane Type

- MLEB** MLE 0.2/0.1 µm
- MLES** MLE 0.45/0.1 µm



Sterilization

- A** Autoclavable
- G** Gamma Compatible
- S** Sterile



Quantity/Package

- 1** 1 /pkg



Pharmaceutical Grade

## Mycoplasma Removal Filter Series

# Purcise MEC Filter

## Hydrophilic Filter with High Mycoplasma Retention Rate



### Features

Low cytotoxicity  
Low adsorption

### Typical Applications

Mycoplasma filtration of culture media

### Quality Control

100% integrity testing in manufacturing  
Each filter is fully traceable with unique serial number  
ISO 9001:2015 manufacturing facility

### Removal Rating and Effective Filtration Area

|                              | MECB(0.2/0.1 µm)    | MECS(0.45/0.1 µm)   |
|------------------------------|---------------------|---------------------|
| A - Standard Cartridge (10") | 0.55 m <sup>2</sup> | 0.55 m <sup>2</sup> |

### Materials of Construction

|                           |   |
|---------------------------|---|
| Membrane                  | Hydrophilic polyethersulfone (PES)                              |
| Support                   | Polypropylene (PP)  |
| Core/Cage/End Caps        | Polypropylene (PP)  |
| Cartridge End Cap Inserts | Polybutylene terephthalate (PBT)<br>(Cartridge exclusive)       |
| Cartridge End Cap O-rings | Silicone / EPDM / Fluoroelastomer /<br>PFA encapsulated O-rings |
| Capsule Housing           | Polypropylene (PP)  |
| Capsule Vent O-rings      | Silicone  |

### Maximum Differential Pressure

|                        |  |
|------------------------|--|
| A - Standard Cartridge | Forward: 0.69 MPa @ 25 °C, 0.40 MPa @ 60 °C, 0.24 MPa @ 80 °C<br>Reverse: 0.30 MPa @ 25 °C, 0.10 MPa @ 80 °C |
| Capsule                | Forward: 0.55 MPa @ 25 °C, 0.1 MPa @ 80 °C<br>Reverse: 0.21 MPa @ 25 °C                                      |

### Integrity Test Standards

|  |   |
|--|---|
| Standard - 10inch<br>(0.55m <sup>2</sup> ) | Bubble Point @20 °C ≥ 0.27 MPa, 60% IPA 40% air, wetted with water<br>Air Diffusion @20 °C ≤ 30 ml/min @0.35 MPa, wetted with water |
|--|---|

### Sterilization

|                        |  |
|------------------------|--|
| A - Standard Cartridge | Can be steam sterilized for 30 minutes at 135 °C with 50 cycles (< 30 kPa)<br>Can be autoclaved 50 cycles for 30 minutes at 130 °C   |
| Capsule                | Autoclavable capsules only: Can be autoclaved 25 cycles for 30 minutes at 130 °C, (Can not be steam sterilized in-line)<br>Gamma compatible capsules: Can be sterilized by gamma irradiation at 25-45 kGy or can be autoclaved 5 cycles for 60 minutes at 126 °C. (Can not be steamed in-line)<br>Sterile capsule: Can be sterilized by gamma irradiation at 25-45 kGy<br>Cleansteam bag sterile package: Pre-sterilized with autoclave for 30 minutes at 121 °C |

Notes: Gamma sterilized products cannot be re-sterilized with gamma irradiation or steam sterilization



## Flow Rates

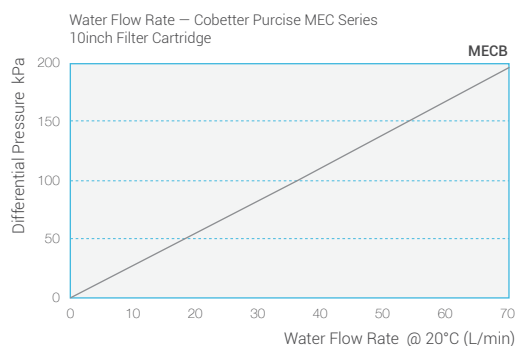

## Regulatory Compliance

- Effluent meets the USP<788> requirement of particulate matter in large volume injection.
- Component materials meet the criteria for a "Non-fiber-releasing filter" as defined in 21 CFR 210.3(b)(6).
- Retention of  $10^7$  cfu/cm<sup>2</sup> *Brevundimonas diminuta* (ATCC 19146) according to ASTM F838
- Typical Log Reduction Value (LRV) >7 of *Acholeplasma laidlawii* (ATCC 23206) according to ASTM F838
- Aqueous extraction from a cartridge contains less than 0.25EU/ml as determined by Limulus Amebocyte Lysate (LAL), meeting requirements of USP<85>.
- Components meet the requirement of USP <87> In Vitro Biological Reactivity Test.
- Components meet the criteria of the USP <88> Biological Reactivity Test for Class V-121 °C plastics.
- Components meet the FDA indirect Food Additive requirements cited in 21 CFR177-182.
- Based on the current information from our suppliers, all components used in the manufacture of this product are animal-free.

Notes: Contact Cobetter for more specification details.

## Purcise MEC Filter

### Ordering Information

#### Filter Cartridge



Cartridge Format

**A** Standard Cartridge



Membrane Type

**MECB** MEC 0.2/0.1 µm  
**MECS** MEC 0.45/0.1 µm



Length

**02** 2.5 inch  
**05** 5 inch  
**10** 10 inch  
**20** 20 inch  
**30** 30 inch  
**40** 40 inch



Code

**0** DOE  
**2** 226 / Flat  
**7** 226 / Fin  
**3** 222 / Flat  
**8** 222 / Fin  
**6** 222 / 3-Flange bayonet / Fin



O-ring Material

**S** Silicone  
**E** EPDM  
**V** Fluoroelastomer  
**P** FEP/PFA encapsulated O-rings



Pharmaceutical Grade

#### Bricap C Series Capsule Filter



Capsule Format

**C01** Bricap C01  
**C02** Bricap C02  
**C03** Bricap C03



Inlet/Outlet

**T** 19 mm (3/4") Sanitary Flange  
**K** 14 mm (9/16") Sanitary Flange  
**F** 31 mm (1 1/4") Sanitary Flange  
**V** 14 mm (9/16") Hose Barb  
**H** 13 mm (1/2") Hose Barb  
**Y** 9.6 mm (3/8") Hose Barb  
**L** 3.2 mm (1/8") Hose Barb  
**B** 6-13 mm (1/4"-1/2") Stepped Hose Barb (No Filling Bell)  
**A** 6-13 mm (1/4"-1/2") Stepped Hose Barb with Filling Bell (Outlet only)

#### Bricap D Series Capsule Filter



Capsule Format

**D01** Bricap D01



Inlet/Outlet

**B** 6-13 mm (1/4"-1/2") Stepped Hose Barb (No Filling Bell)  
**A** 6-13 mm (1/4"-1/2") Stepped Hose Barb with Filling Bell (Outlet only)

#### Bricap L Series Capsule Filter



Housing Type

**Blank** Standard  
**K** Transparent



Capsule Format

**L02** Bricap L02  
**L03** Bricap L03  
**L05** Bricap L05  
**L10** Bricap L10  
**L20** Bricap L20  
**L30** Bricap L30



Inlet/Outlet

**S** 38 mm (1 1/2") Sanitary Flange  
**T** 19 mm (3/4") Sanitary Flange  
**K** 14 mm (9/16") Sanitary Flange  
**D** 25 mm (1") Hose Barb  
**M** 19 mm (3/4") Hose Barb  
**X** 16 mm (5/8") Hose Barb  
**V** 14 mm (9/16") Hose Barb  
**H** 13 mm (1/2") Hose Barb  
**Y** 9.6 mm (3/8") Hose Barb

#### Bricap T Series Capsule Filter



Capsule Format

**T10** Bricap T10  
**T20** Bricap T20  
**T30** Bricap T30



Inlet/Outlet

**SS** 38 mm (1 1/2") Sanitary Flange Inlet & Outlet  
**SM** 38 mm (1 1/2") Sanitary Flange Inlet & 19 mm (3/4") Hose Barb Outlet



Gauge Port Type

**S** 38 mm (1 1/2") Sanitary Flange  
**T** 19 mm (3/4") Sanitary Flange  
**N** Without Gauge Port

|   |   |                  |                      |
|---|---|------------------|----------------------|
|   |   |                  |                      |
| Membrane Type   | Sterilization   | Quantity/Package | Pharmaceutical Grade |
| <b>MECB</b> MEC 0.2/0.1 µm<br><b>MECS</b> MEC 0.45/0.1 µm | <b>A</b> Autoclavable<br><b>G</b> Gamma Compatible<br><b>S</b> Sterile<br><b>C</b> Cleansteam Bag Sterile Package | <b>1</b> 1 /pkg  | Pharmaceutical Grade |

### BriScale A50 Liquid Disc Filter



Disc Filter Format

**A50** BriScale A50



Inlet/Outlet

**BB** 6-13 mm (1/4"-1/2") Stepped Hose Barb Inlet and Outlet (No Filling Bell)  
**BA** 6-13 mm (1/4"-1/2") Stepped Hose Barb Inlet and Outlet (Outlet with Filling Bell)

### Bricap SFU Series Syringe Filter (No Vent)



Syringe Filter Format

**U13** Bricap SFU13  
**U25** Bricap SFU25  
**U33** Bricap SFU33



Inlet/Outlet

**CP** Female luer lock inlet and male luer lock outlet

### Bricap SFV Series Syringe Filter (With Luer Vent)



Syringe Filter Format

**V25** Bricap SFV25



Inlet/Outlet

**CP** Female luer lock inlet and male luer lock outlet



Membrane Type

**MECB** MEC 0.2/0.1 µm  
**MECS** MEC 0.45/0.1 µm



Sterilization

**A** Autoclavable  
**G** Gamma Compatible  
**S** Sterile



Quantity/Package

**1** 1 /pkg



Pharmaceutical Grade

## Prefiltration and Bioburden Reduction Series

# Safetect PME Filter

## Hydrophilic Filter with High Dirt-Holding Capacity



### Features

Double-layer design  
 Extensive chemical compatibility  
 High dirt-holding and loading capacity, high flow rate,  
 high bacterial retention capacity

### Typical Applications

Terminal sterilization protection  
 Pre-filtration of mycoplasma removal  
 Buffer Filtration

### Quality Control

100% integrity testing in manufacturing  
 Each filter is fully traceable with unique serial number  
 ISO 9001:2015 manufacturing facility

### Removal Rating and Effective Filtration Area

|                                 | PMEA(0.8/0.1 µm Nominal) | PMEB(1.0/0.2 µm Nominal) | PMES(1.0/0.45 µm)   |
|---------------------------------|--------------------------|--------------------------|---------------------|
| A - Standard Cartridge (10")    | 0.55 m <sup>2</sup>      | 0.55 m <sup>2</sup>      | 0.55 m <sup>2</sup> |
| H - High Area Cartridge 1 (10") | 0.8 m <sup>2</sup>       | 0.8 m <sup>2</sup>       | 0.8 m <sup>2</sup>  |
| L - High Area Cartridge 2 (10") | 1.04 m <sup>2</sup>      | 1.04 m <sup>2</sup>      | 1.04 m <sup>2</sup> |

### Materials of Construction

|                           |   |
|---------------------------|---|
| Membrane                  | Hydrophilic polyethersulfone (PES)                              |
| Support                   | Polypropylene (PP)  |
| Core/Cage/End Caps        | Polypropylene (PP)  |
| Cartridge End Cap Inserts | Polybutylene terephthalate (PBT)<br>(Cartridge exclusive)       |
| Cartridge End Cap O-rings | Silicone / EPDM / Fluoroelastomer /<br>PFA encapsulated O-rings |
| Capsule Housing           | Polypropylene (PP)  |
| Capsule Vent O-rings      | Silicone  |
| SP3 Capsule Port Insert   | 316L Stainless Steel  |
| SP3 Capsule Housing       | Polyetherimide (PEI)  |
| SP3 Capsule O-rings       | Silicone  |

### Maximum Differential Pressure

|                           |  |
|---------------------------|--|
| A - Standard Cartridge/   | Forward: 0.69 MPa @ 25 °C, 0.40 MPa @ 60 °C, 0.24 MPa @ 80 °C  |
| H - High Area Cartridge 1 | Reverse: 0.30 MPa @ 25 °C, 0.10 MPa @ 80 °C  |
| L - High Area Cartridge 2 | Forward: 0.55 MPa @ 25 °C, 0.40 MPa @ 60 °C, 0.24 MPa @ 80 °C<br>Reverse: 0.30 MPa @ 25 °C, 0.10 MPa @ 80 °C |
| Capsule                   | Forward: 0.55 MPa @ 25 °C, 0.1 MPa @ 80 °C<br>Reverse: 0.21 MPa @ 25 °C                                      |

### Integrity Test Standards

|  |   |
|--|---|
| Standard - 10inch<br>(0.55m <sup>2</sup> ) | PMEA: Bubble Point@20 °C ≥ 0.3 MPa, air, wetted with water<br>PMEB: Bubble Point@20 °C ≥ 0.27 MPa, air, wetted with water<br>PMES: Bubble Point@20 °C ≥ 0.2 MPa, air, wetted with water |
|--|---|

### Sterilization

|  |  |
|--|--|
| A - Standard Cartridge/<br>H - High Area Cartridge 1 | Can be steam sterilized for 30 minutes at 135 °C with 50 cycles (< 30 kPa)<br>Can be autoclaved 50 cycles for 30 minutes at 130 °C   |
| L - High Area Cartridge 2                            | Can be steam sterilized for 30 minutes at 135 °C with 25 cycles (< 30 kPa)<br>Can be autoclaved 25 cycles for 30 minutes at 130 °C   |
| Capsule  | Autoclavable capsules only: Can be autoclaved 25 cycles for 30 minutes at 130 °C, (Can not be steam sterilized in-line)<br>Gamma compatible capsules: Can be sterilized by gamma irradiation at 25-45 kGy or can be autoclaved 5 cycles for 60 minutes at 126 °C. (Can not be steamed in-line)<br>Sterile capsule: Can be sterilized by gamma irradiation at 25-45 kGy<br>Cleansteam bag sterile package: Pre-sterilized with autoclave for 30 minutes at 121 °C |

Notes: Gamma sterilized products cannot be re-sterilized with gamma irradiation or steam sterilization

## Flow Rates

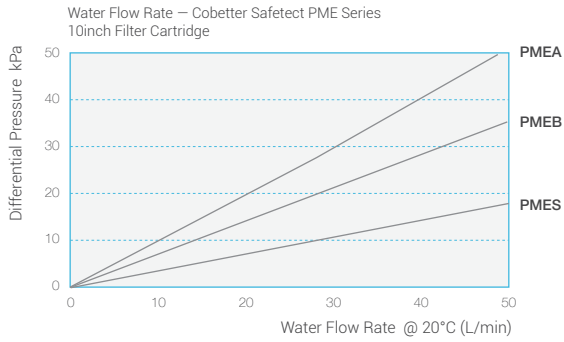

## Regulatory Compliance

- Effluent meets the USP<788> requirement of particulate matter in large volume injection.
- Component materials meet the criteria for a "Non-fiber-releasing filter" as defined in 21 CFR 210.3(b)(6).
- Retention of  $10^7$  cfu/cm<sup>2</sup> *Brevundimonas diminuta* (ATCC 19146) according to ASTM F838 for Cobetter Safetect PME 0.8/0.1 N
- Retention of  $10^7$  cfu/cm<sup>2</sup> *Serratia marcescens* (ATCC 14756) according to ASTM F838 for Cobetter Safetect PME 1.0/0.45 N
- Aqueous extraction from a cartridge contains less than 0.25EU/ml as determined by Limulus Amebocyte Lysate (LAL), meeting requirements of USP<85>.
- Components meet the requirement of USP <87> In Vitro Biological Reactivity Test.
- Components meet the criteria of the USP <88> Biological Reactivity Test for Class V-121 °C plastics.
- Components meet the FDA indirect Food Additive requirements cited in 21 CFR 177-182.
- Based on the current information from our suppliers, all components used in the manufacture of this product are animal-free.

Notes: Contact Cobetter for more specification details.

## Prefiltration and Bioburden Reduction Series

# Purcise PLE Filter

## Hydrophilic Filter with Low Protein Adsorption



### Features

- Double-layer design
- Reliable retention of bacteria and particles
- Extensive chemical compatibility
- Low leachables
- Low protein adsorption

### Typical Applications

- Buffer filtration
- Pre-column/ultra-filtration protection

### Quality Control

- 100% integrity testing in manufacturing
- Each filter is fully traceable with unique serial number
- ISO 9001:2015 manufacturing facility

### Removal Rating and Effective Filtration Area

|                                 | PLES(0.8/0.45 µm)   | PLEH(1.0/0.65 µm)   | PLEL(1.5/0.8 µm)    |
|---------------------------------|---------------------|---------------------|---------------------|
| A - Standard Cartridge (10")    | 0.55 m <sup>2</sup> | 0.55 m <sup>2</sup> | 0.55 m <sup>2</sup> |
| H - High Area Cartridge 1 (10") | 0.8 m <sup>2</sup>  | 0.8 m <sup>2</sup>  | 0.8 m <sup>2</sup>  |
| L - High Area Cartridge 2 (10") | 1.04 m <sup>2</sup> | 1.04 m <sup>2</sup> | 1.04 m <sup>2</sup> |

### Materials of Construction

|                           |   |
|---------------------------|---|
| Membrane                  | Hydrophilic polyethersulfone (PES)                              |
| Support                   | Polypropylene (PP)  |
| Core/Cage/End Caps        | Polypropylene (PP)  |
| Cartridge End Cap Inserts | Polybutylene terephthalate (PBT)<br>(Cartridge exclusive)       |
| Cartridge End Cap O-rings | Silicone / EPDM / Fluoroelastomer /<br>PFA encapsulated O-rings |
| Capsule Housing           | Polypropylene (PP)  |
| Capsule Vent O-rings      | Silicone  |
| SP3 Capsule Port Insert   | 316L Stainless Steel  |
| SP3 Capsule Housing       | Polyetherimide (PEI)  |
| SP3 Capsule O-rings       | Silicone  |

### Maximum Differential Pressure

|                           |  |
|---------------------------|--|
| A - Standard Cartridge/   | Forward: 0.69 MPa @ 25 °C, 0.40 MPa @ 60 °C, 0.24 MPa @ 80 °C  |
| H - High Area Cartridge 1 | Reverse: 0.30 MPa @ 25 °C, 0.10 MPa @ 80 °C  |
| L - High Area Cartridge 2 | Forward: 0.55 MPa @ 25 °C, 0.40 MPa @ 60 °C, 0.24 MPa @ 80 °C<br>Reverse: 0.30 MPa @ 25 °C, 0.10 MPa @ 80 °C |
| Capsule                   | Forward: 0.55 MPa @ 25 °C, 0.1 MPa @ 80 °C<br>Reverse: 0.21 MPa @ 25 °C                                      |

### Integrity Test Standards

|   |   |
|---|---|
| Standard - 10inch (0.55m <sup>2</sup> ) | PLES: Bubble Point@20 °C ≥ 0.27 MPa, air, wetted with water<br>PLEH: Bubble Point@20 °C ≥ 0.2 MPa, air, wetted with water<br>PLEL: Bubble Point@20 °C ≥ 0.1 MPa, air, wetted with water |
|---|---|

### Sterilization

|  |  |
|--|--|
| A - Standard Cartridge/<br>H - High Area Cartridge 1 | Can be steam sterilized for 30 minutes at 135 °C with 50 cycles (< 30 kPa)<br>Can be autoclaved 50 cycles for 30 minutes at 130 °C   |
| L - High Area Cartridge 2                            | Can be steam sterilized for 30 minutes at 135 °C with 25 cycles (< 30 kPa)<br>Can be autoclaved 25 cycles for 30 minutes at 130 °C   |
| Capsule  | Autoclavable capsules only: Can be autoclaved 25 cycles for 30 minutes at 130 °C, (Can not be steam sterilized in-line)<br>Gamma compatible capsules: Can be sterilized by gamma irradiation at 25-45 kGy or can be autoclaved 5 cycles for 60 minutes at 126 °C. (Can not be steamed in-line)<br>Sterile capsule: Can be sterilized by gamma irradiation at 25-45 kGy<br>Cleansteam bag sterile package: Pre-sterilized with autoclave for 30 minutes at 121 °C |

Notes: Gamma sterilized products cannot be re-sterilized with gamma irradiation or steam sterilization



## Flow Rates

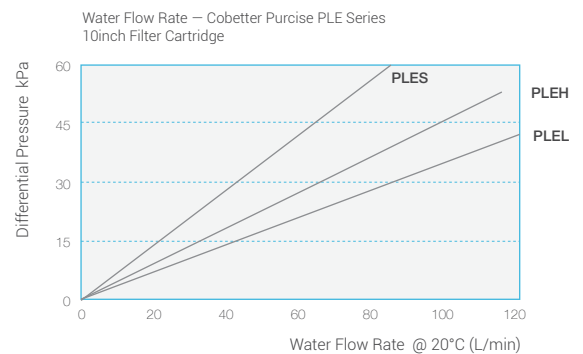
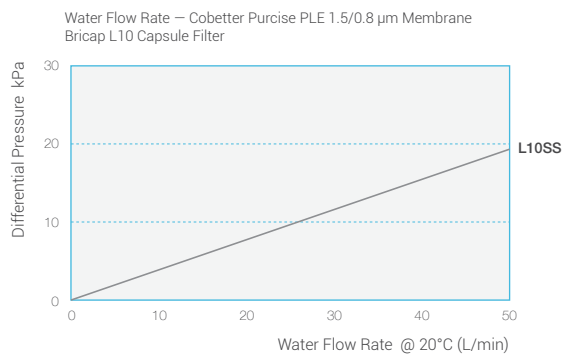
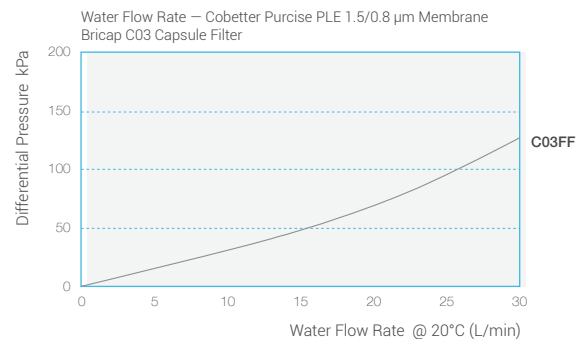
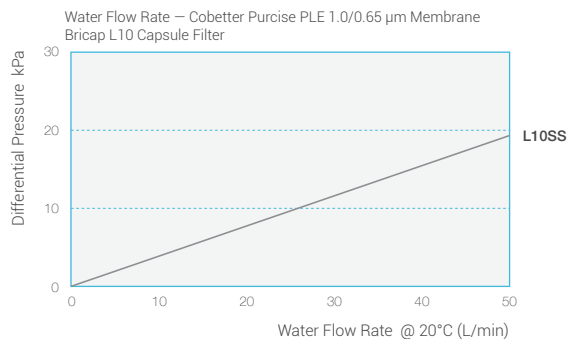
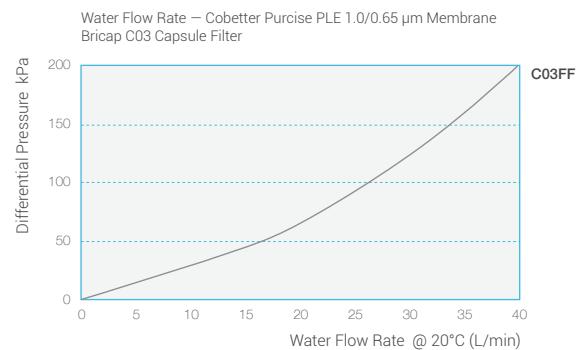
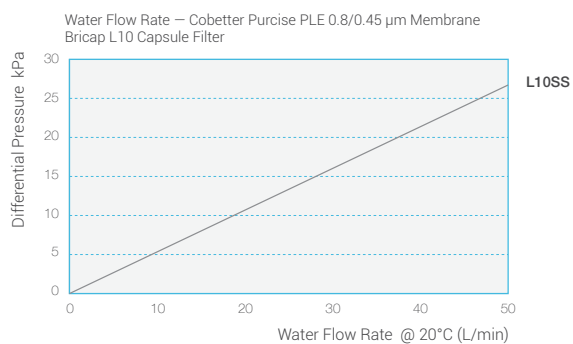

## Regulatory Compliance

- Effluent meets the USP<788> requirement of particulate matter in large volume injection.
- Component materials meet the criteria for a "Non-fiber-releasing filter" as defined in 21 CFR 210.3(b)(6).
- Typical Log Reduction Value(LRV)>6 using Brevundimonas diminuta(ATCC19146) according to ASTM F838
- Aqueous extraction from a cartridge contains less than 0.25EU/ml as determined by Limulus Amebocyte Lysate (LAL), meeting requirements of USP<85>.
- Components meet the requirement of USP <87> In Vitro Biological Reactivity Test.
- Components meet the criteria of the USP <88> Biological Reactivity Test for Class V-121 °c plastics.
- Components meet the FDA indirect Food Additive requirements cited in 21 CFR177-182.
- Based on the current information from our suppliers, all components used in the manufacture of this product are animal-free.

Notes: Contact Cobetter for more specification details.

## Prefiltration and Bioburden Reduction Series

# Purcise PAF Filter

## Hydrophilic Filter with High Flow Rate



### Features

Reliable retention of bacteria and particles  
Extensive chemical compatibility  
High flow rate, high throughput

### Typical Applications

Buffer Filtration

### Quality Control

100% integrity testing in manufacturing  
Each filter is fully traceable with unique serial number  
ISO 9001:2015 manufacturing facility

### Removal Rating and Effective Filtration Area

|                                 | PAFS(0.45 µm)       | PAFH(0.65 µm)       | PAFL(0.8 µm)        | PAFP(1.0 µm)        | PAFC(1.2 µm)        |
|---------------------------------|---------------------|---------------------|---------------------|---------------------|---------------------|
| A - Standard Cartridge (10")    | 0.55 m <sup>2</sup> | 0.55 m <sup>2</sup> | 0.55 m <sup>2</sup> | 0.55 m <sup>2</sup> | 0.55 m <sup>2</sup> |
| H - High Area Cartridge 1 (10") | 0.8 m <sup>2</sup>  | 0.8 m <sup>2</sup>  | 0.8 m <sup>2</sup>  | 0.8 m <sup>2</sup>  | 0.8 m <sup>2</sup>  |
| L - High Area Cartridge 2 (10") | 1.04 m <sup>2</sup> | 1.04 m <sup>2</sup> | 1.04 m <sup>2</sup> | 1.04 m <sup>2</sup> | 1.04 m <sup>2</sup> |

### Materials of Construction

|                           |   |
|---------------------------|---|
| Membrane                  | Hydrophilic polyethersulfone (PES)                              |
| Support                   | Polypropylene (PP)  |
| Core/Cage/End Caps        | Polypropylene (PP)  |
| Cartridge End Cap Inserts | Polybutylene terephthalate (PBT)<br>(Cartridge exclusive)       |
| Cartridge End Cap O-rings | Silicone / EPDM / Fluoroelastomer /<br>PFA encapsulated O-rings |
| Capsule Housing           | Polypropylene (PP)  |
| Capsule Vent O-rings      | Silicone  |
| SP3 Capsule Port Insert   | 316L Stainless Steel  |
| SP3 Capsule Housing       | Polyetherimide (PEI)  |
| SP3 Capsule O-rings       | Silicone  |

### Maximum Differential Pressure

|  |  |
|--|--|
| A - Standard Cartridge/<br>H - High Area Cartridge 1 | Forward: 0.69 MPa @ 25 °C, 0.40 MPa @ 60 °C, 0.24 MPa @ 80 °C<br>Reverse: 0.30 MPa @ 25 °C, 0.10 MPa @ 80 °C |
| L - High Area Cartridge 2                            | Forward: 0.55 MPa @ 25 °C, 0.40 MPa @ 60 °C, 0.24 MPa @ 80 °C<br>Reverse: 0.30 MPa @ 25 °C, 0.10 MPa @ 80 °C |
| Capsule  | Forward: 0.55 MPa @ 25 °C, 0.1 MPa @ 80 °C<br>Reverse: 0.21 MPa @ 25 °C                                      |

### Integrity Test Standards

|  |   |
|--|---|
| Standard - 10inch<br>(0.55m <sup>2</sup> ) | PAFS: Bubble Point@20 °C≥ 0.27 MPa, air, wetted with water<br>PAFH: Bubble Point@20 °C≥ 0.12 MPa, air, wetted with water<br>PAFL: Bubble Point@20 °C≥ 0.1 MPa, air, wetted with water |
|--|---|

### Sterilization

|  |  |
|--|--|
| A - Standard Cartridge/<br>H - High Area Cartridge 1 | Can be steam sterilized for 30 minutes at 135 °C with 50 cycles (< 30 kPa)<br>Can be autoclaved 50 cycles for 30 minutes at 130 °C   |
| L - High Area Cartridge 2                            | Can be steam sterilized for 30 minutes at 135 °C with 25 cycles (< 30 kPa)<br>Can be autoclaved 25 cycles for 30 minutes at 130 °C   |
| Capsule  | Autoclavable capsules only: Can be autoclaved 25 cycles for 30 minutes at 130 °C, (Can not be steam sterilized in-line)<br>Gamma compatible capsules: Can be sterilized by gamma irradiation at 25-45 kGy or can be autoclaved 5 cycles for 60 minutes at 126 °C. (Can not be steamed in-line)<br>Sterile capsule: Can be sterilized by gamma irradiation at 25-45 kGy<br>Cleansteam bag sterile package: Pre-sterilized with autoclave for 30 minutes at 121 °C |

Notes: Gamma sterilized products cannot be re-sterilized with gamma irradiation or steam sterilization

## Flow Rates

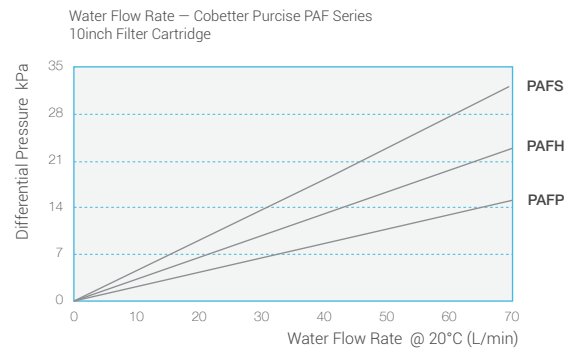
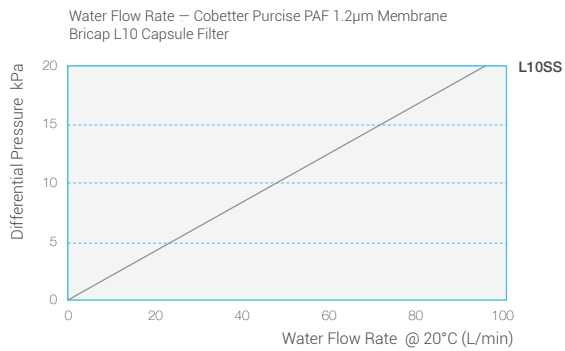
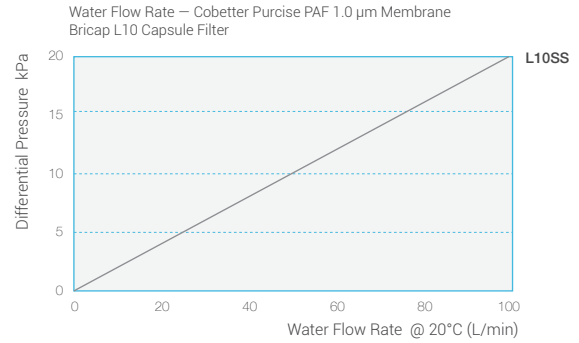
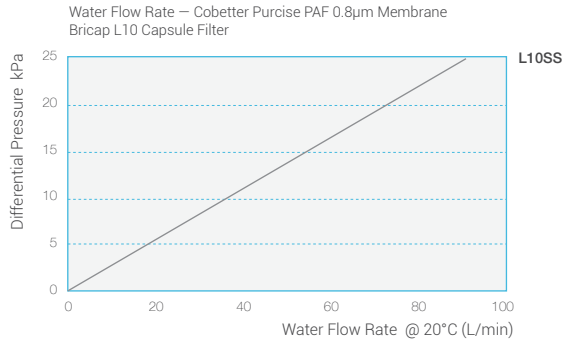
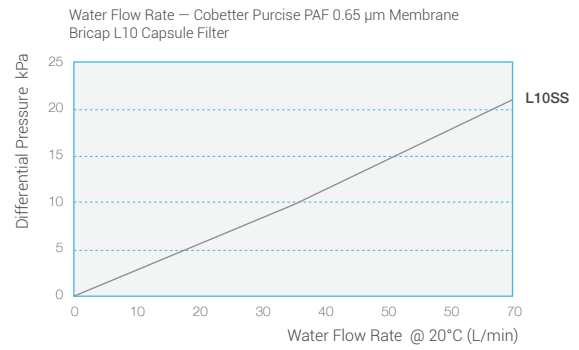
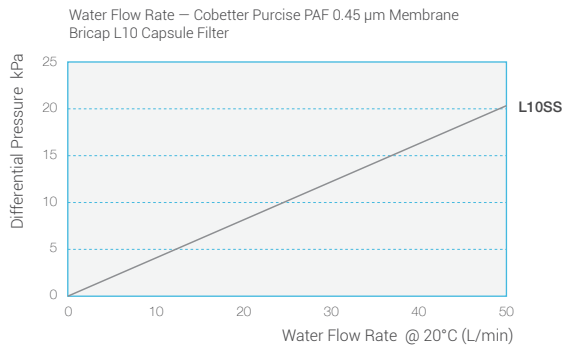

## Regulatory Compliance

- Effluent meets the USP<788> requirement of particulate matter in large volume injection.
- Component materials meet the criteria for a "Non-fiber-releasing filter" as defined in 21 CFR 210.3(b)(6).
- Retention of  $10^7$  cfu/cm<sup>2</sup> Serratia marcescens (ATCC 14756) according to ASTM F838
- Aqueous extraction from a cartridge contains less than 0.25EU/ml as determined by Limulus Amebocyte Lysate (LAL), meeting requirements of USP<85>.
- Components meet the requirement of USP <87> In Vitro Biological Reactivity Test.
- Components meet the criteria of the USP <88> Biological Reactivity Test for Class V-121 °C plastics.
- Components meet the FDA indirect Food Additive requirements cited in 21 CFR 177-182.
- Based on the current information from our suppliers, all components used in the manufacture of this product are animal-free.

Notes: Contact Cobetter for more specification details.

## Prefiltration and Bioburden Reduction Series

# Purcise PEHS Filter

## Hydrophilic Filter with High Flow Rate



### Features

- Double-layer design
- Reliable retention of bacteria and particles
- Extensive chemical compatibility
- Low leachables

### Typical Applications

- Pre-filtration of eye drops

### Quality Control

- 100% integrity testing in manufacturing
- Each filter is fully traceable with unique serial number
- ISO 9001:2015 manufacturing facility

### Removal Rating and Effective Filtration Area

|                                 | PEHS(0.8/0.45 µm)   |
|---------------------------------|---------------------|
| A - Standard Cartridge (10")    | 0.55 m <sup>2</sup> |
| H - High Area Cartridge 1 (10") | 0.8 m <sup>2</sup>  |
| L - High Area Cartridge 2 (10") | 1.04 m <sup>2</sup> |

### Materials of Construction

|                           |   |
|---------------------------|---|
| Membrane                  | Hydrophilic polyethersulfone (PES)                              |
| Support                   | Polypropylene (PP)  |
| Core/Cage/End Caps        | Polypropylene (PP)  |
| Cartridge End Cap Inserts | Polybutylene terephthalate (PBT)<br>(Cartridge exclusive)       |
| Cartridge End Cap O-rings | Silicone / EPDM / Fluoroelastomer /<br>PFA encapsulated O-rings |
| Capsule Housing           | Polypropylene (PP)  |
| Capsule Vent O-rings      | Silicone  |
| SP3 Capsule Port Insert   | 316L Stainless Steel  |
| SP3 Capsule Housing       | Polyetherimide (PEI)  |
| SP3 Capsule O-rings       | Silicone  |

### Maximum Differential Pressure

|                           |  |
|---------------------------|--|
| A - Standard Cartridge/   | Forward: 0.69 MPa @ 25 °C, 0.40 MPa @ 60 °C, 0.24 MPa @ 80 °C  |
| H - High Area Cartridge 1 | Reverse: 0.30 MPa @ 25 °C, 0.10 MPa @ 80 °C  |
| L - High Area Cartridge 2 | Forward: 0.55 MPa @ 25 °C, 0.40 MPa @ 60 °C, 0.24 MPa @ 80 °C<br>Reverse: 0.30 MPa @ 25 °C, 0.10 MPa @ 80 °C |
| Capsule                   | Forward: 0.55 MPa @ 25 °C, 0.1 MPa @ 80 °C<br>Reverse: 0.21 MPa @ 25 °C                                      |

### Integrity Test Standards

|   |   |
|---|---|
| Standard - 10inch (0.55m <sup>2</sup> ) | Bubble Point@20 °C ≥ 0.27 MPa, air, wetted with water |
|---|---|

## Sterilization

|  |  |
|--|--|
| A - Standard Cartridge/<br>H - High Area Cartridge 1 | Can be steam sterilized for 30 minutes at 135 °C with 50 cycles (< 30 kPa)<br>Can be autoclaved 50 cycles for 30 minutes at 130°C  |
| L - High Area Cartridge 2                            | Can be steam sterilized for 30 minutes at 135 °C with 30 cycles (< 30 kPa)<br>Can be autoclaved 30 cycles for 30 minutes at 130°C  |
| Capsule  | Autoclavable capsules only: Can be autoclaved 25 cycles for 30 minutes at 130°C, (Can not be steam sterilized in-line)<br>Gamma compatible capsules: Can be sterilized by gamma irradiation at 25-45 kGy or can be autoclaved 5 cycles for 60 minutes at 126 °C. (Can not be steamed in-line)<br>Sterile capsule: Can be sterilized by gamma irradiation at 25-45 kGy<br>Cleansteam bag sterile package: Pre-sterilized with autoclave for 30 minutes at 121°C |

Notes: Gamma sterilized products cannot be re-sterilized with gamma irradiation or steam sterilization

## Flow Rates

Water Flow Rate – Cobetter Purcise PEH 0.8/ 0.45 µm Membrane  
10inch Filter Cartridge

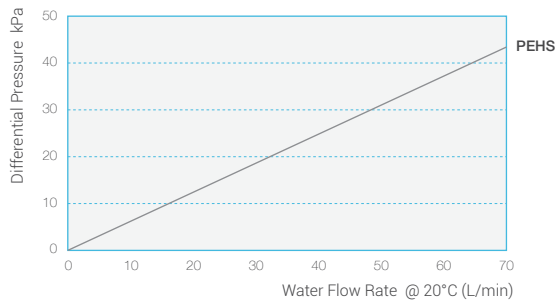

## Regulatory Compliance

- Effluent meets the USP<788> requirement of particulate matter in large volume injection.
- Component materials meet the criteria for a "Non-fiber-releasing filter" as defined in 21 CFR 210.3(b)(6).
- Retention of  $10^7$  cfu/cm<sup>2</sup> *Serratia marcescens* (ATCC 14756) according to ASTM F838
- Aqueous extraction from a cartridge contains less than 0.25EU/ml as determined by Limulus Amebocyte Lysate (LAL), meeting requirements of USP<85>.
- Components meet the requirement of USP <87> In Vitro Biological Reactivity Test.
- Components meet the criteria of the USP <88> Biological Reactivity Test for Class V-121 °C plastics.
- Components meet the FDA indirect Food Additive requirements cited in 21 CFR177-182.
- Based on the current information from our suppliers, all components used in the manufacture of this product are animal-free.

Notes: Contact Cobetter for more specification details.

## Prefiltration and Bioburden Reduction Series

# Purcise PEAB Filter

## Hydrophilic Filter with High Flow Rate



### Features

Double-layer design  
 Reliable retention of bacteria and particles  
 Extensive chemical compatibility  
 Low leachables

### Typical Applications

Animal vaccine filtration  
 Filtration of paclitaxel-albumin solution

### Quality Control

100% integrity testing in manufacturing  
 Each filter is fully traceable with unique serial number  
 ISO 9001:2015 manufacturing facility

### Removal Rating and Effective Filtration Area

|                                 | PEAB(1.0/0.2 µm Nominal) |
|---------------------------------|--------------------------|
| A - Standard Cartridge (10")    | 0.55 m <sup>2</sup>      |
| H - High Area Cartridge 1 (10") | 0.8 m <sup>2</sup>       |
| L - High Area Cartridge 2 (10") | 1.04 m <sup>2</sup>      |

### Materials of Construction

|                           |   |
|---------------------------|---|
| Membrane                  | Hydrophilic polyethersulfone (PES)                              |
| Support                   | Polypropylene (PP)  |
| Core/Cage/End Caps        | Polypropylene (PP)  |
| Cartridge End Cap Inserts | Polybutylene terephthalate (PBT)<br>(Cartridge exclusive)       |
| Cartridge End Cap O-rings | Silicone / EPDM / Fluoroelastomer /<br>PFA encapsulated O-rings |
| Capsule Housing           | Polypropylene (PP)  |
| Capsule Vent O-rings      | Silicone  |
| SP3 Capsule Port Insert   | 316L Stainless Steel  |
| SP3 Capsule Housing       | Polyetherimide (PEI)  |
| SP3 Capsule O-rings       | Silicone  |

### Maximum Differential Pressure

|  |  |
|--|--|
| A - Standard Cartridge/<br>H - High Area Cartridge 1 | Forward: 0.69 MPa @ 25 °C, 0.40 MPa @ 60 °C, 0.24 MPa @ 80 °C<br>Reverse: 0.30 MPa @ 25 °C, 0.10 MPa @ 80 °C |
| L - High Area Cartridge 2                            | Forward: 0.55 MPa @ 25 °C, 0.40 MPa @ 60 °C, 0.24 MPa @ 80 °C<br>Reverse: 0.30 MPa @ 25 °C, 0.10 MPa @ 80 °C |
| Capsule  | Forward: 0.55 MPa @ 25 °C, 0.1 MPa @ 80 °C<br>Reverse: 0.21 MPa @ 25 °C                                      |

### Integrity Test Standards

|  |   |
|--|---|
| Standard - 10inch<br>(0.55m <sup>2</sup> ) | Bubble Point@20 °C ≥ 0.27 MPa, air, wetted with water |
|--|---|



## Sterilization

|  |   |
|--|---|
| A - Standard Cartridge/<br>H - High Area Cartridge 1 | Can be steam sterilized for 30 minutes at 135 °C with 50 cycles (< 30 kPa)<br>Can be autoclaved 50 cycles for 30 minutes at 130°C                                   |
| L - High Area Cartridge 2                            | Can be steam sterilized for 30 minutes at 135 °C with 30 cycles (< 30 kPa)<br>Can be autoclaved 30 cycles for 30 minutes at 130°C                                   |
| Capsule  | Autoclavable capsules only: Can be autoclaved 25 cycles for 30 minutes at 130°C, (Can not be steam sterilized in-line)  |
|  | Gamma compatible capsules: Can be sterilized by gamma irradiation at 25-45 kGy or can be autoclaved 5 cycles for 60 minutes at 126 °C. (Can not be steamed in-line) |
|  | Sterile capsule: Can be sterilized by gamma irradiation at 25-45 kGy  |
|  | Cleansteam bag sterile package: Pre-sterilized with autoclave for 30 minutes at 121 °C  |

Notes: Gamma sterilized products cannot be re-sterilized with gamma irradiation or steam sterilization

## Flow Rates

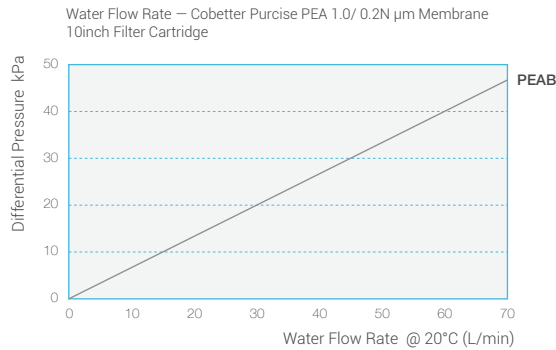

## Regulatory Compliance

- Effluent meets the USP<788> requirement of particulate matter in large volume injection.
- Component materials meet the criteria for a "Non-fiber-releasing filter" as defined in 21 CFR 210.3(b)(6).
- Retention of  $10^7$  cfu/cm<sup>2</sup> *Serratia marcescens* (ATCC 14756) according to ASTM F838
- Aqueous extraction from a cartridge contains less than 0.25EU/ml as determined by Limulus Amebocyte Lysate (LAL), meeting requirements of USP<85>.
- Components meet the requirement of USP <87> In Vitro Biological Reactivity Test.
- Components meet the criteria of the USP <88> Biological Reactivity Test for Class V-121 °C plastics.
- Components meet the FDA indirect Food Additive requirements cited in 21 CFR177-182.
- Based on the current information from our suppliers, all components used in the manufacture of this product are animal-free.

Notes: Contact Cobetter for more specification details.

## Safetect PME, Purcise PLE/PAF/PEHS/PEAB Filter

### Ordering Information

#### Filter Cartridge



Cartridge Format

- A** Standard Cartridge
- H** H - High Area Cartridge(0.69-0.8m<sup>2</sup>)
- L** L - High Area Cartridge(1.0-1.2m<sup>2</sup>)



Membrane Type

- PMEA** PME 0.8/0.1 µm Nominal
- PMEB** PME 1.0/0.2 µm Nominal
- PMES** PME 1.0/0.45 µm
- PLES** PLE 0.8/0.45 µm
- PLEH** PLE 1.0/0.65 µm
- PLEL** PLE 1.5/0.8 µm
- PAFS** PAF 0.45 µm
- PAFH** PAF 0.65 µm
- PAFL** PAF 0.8 µm
- PAFP** PAF 1.0 µm
- PAFC** PAF 1.2 µm
- PEHS** PEH 0.8/0.45 µm
- PEAB** PEA 1.0/0.2 µm Nominal



Length

- 02** 2.5 inch
- 05** 5 inch
- 10** 10 inch
- 20** 20 inch
- 30** 30 inch
- 40** 40 inch



Code

- 0** DOE
- 2** 226 / Flat
- 7** 226 / Fin
- 3** 222 / Flat
- 8** 222 / Fin
- 6** 222 / 3-Flange bayonet / Fin



O-ring Material

- S** Silicone
- E** EPDM
- V** Fluoroelastomer
- P** FEP/PFA encapsulated O-rings



Pharmaceutical Grade

#### Bricap C Series Capsule Filter



Housing Type

- Blank** Standard
- K** Transparent



Capsule Format

- C01** Bricap C01
- C02** Bricap C02
- C03** Bricap C03



Inlet/Outlet

- T** 19 mm (3/4") Sanitary Flange
- K** 14 mm (9/16") Sanitary Flange
- F** 31 mm (1 1/4") Sanitary Flange
- V** 14 mm (9/16") Hose Barb
- H** 13 mm (1/2") Hose Barb
- Y** 9.6 mm (3/8") Hose Barb
- L** 3.2 mm (1/8") Hose Barb
- B** 6-13 mm (1/4"-1/2") Stepped Hose Barb (No Filling Bell)
- A** 6-13 mm (1/4"-1/2") Stepped Hose Barb with Filling Bell (Outlet only)

#### Bricap D Series Capsule Filter



Capsule Format

- D01** Bricap D01



Inlet/Outlet

- B** 6-13 mm (1/4"-1/2") Stepped Hose Barb (No Filling Bell)
- A** 6-13 mm (1/4"-1/2") Stepped Hose Barb with Filling Bell (Outlet only)

#### Bricap L Series Capsule Filter



Housing Type

- Blank** Standard
- K** Transparent



Capsule Format

- L02** Bricap L02
- L03** Bricap L03
- L05** Bricap L05
- L10** Bricap L10
- L20** Bricap L20
- L30** Bricap L30



Inlet/Outlet

- S** 38 mm (1 1/2") Sanitary Flange
- T** 19 mm (3/4") Sanitary Flange
- K** 14 mm (9/16") Sanitary Flange
- D** 25 mm (1") Hose Barb
- M** 19 mm (3/4") Hose Barb
- X** 16 mm (5/8") Hose Barb
- V** 14 mm (9/16") Hose Barb
- H** 13 mm (1/2") Hose Barb
- Y** 9.6 mm (3/8") Hose Barb

#### Bricap T Series Capsule Filter



Capsule Format

- T10** Bricap T10
- T20** Bricap T20
- T30** Bricap T30



Inlet/Outlet

- SS** 38 mm (1 1/2") Sanitary Flange Inlet & Outlet
- SM** 38 mm (1 1/2") Sanitary Flange Inlet & 19 mm (3/4") Hose Barb Outlet



Gauge Port Type

- S** 38 mm (1 1/2") Sanitary Flange
- T** 19 mm (3/4") Sanitary Flange
- N** Without Gauge Port



Membrane Type

- PMEA** PME 0.8/0.1 µm Nominal
- PMEB** PME 1.0/0.2 µm Nominal
- PMES** PME 1.0/0.45 µm
- PLES** PLE 0.8/0.45 µm
- PLEH** PLE 1.0/0.65 µm
- PLEL** PLE 1.5/0.8 µm
- PAFS** PAF 0.45 µm
- PAFH** PAF 0.65 µm
- PAFL** PAF 0.8 µm
- PAFP** PAF 1.0 µm
- PAFC** PAF 1.2 µm
- PEHS** PEH 0.8/0.45 µm
- PEAB** PEA 1.0/0.2 µm Nominal



Sterilization

- A** Autoclavable
- G** Gamma Compatible
- S** Sterile
- C** Cleansteam Bag Sterile Package



Quantity/Package

- 1** 1 /pkg



Pharmaceutical Grade

### Bricap HL Series Capsule Filter



Capsule Format

- HL02** Bricap HL02
- HL03** Bricap HL03
- HL05** Bricap HL05
- HL10** Bricap HL10
- HL20** Bricap HL20
- HL30** Bricap HL30



Inlet/Outlet

- S** 38 mm (1 1/2") Sanitary Flange
- T** 19 mm (3/4") Sanitary Flange
- V** 14 mm (9/16") Hose Barb
- D** 25 mm (1") Hose Barb
- H** 13 mm (1/2") Hose Barb
- Y** 9.6 mm (3/8") Hose Barb

### Bricap HT Series Capsule Filter



Capsule Format

- HT02** Bricap HT02
- HT03** Bricap HT03
- HT05** Bricap HT05
- HT10** Bricap HT10
- HT20** Bricap HT20
- HT30** Bricap HT30



Inlet/Outlet

- SS** 38 mm (1 1/2") Sanitary Flange
- SM** 38 mm (1 1/2") Sanitary Flange Inlet and 19 mm (3/4") Hose Barb Outlet



Gauge Port Type

- S** 38 mm (1 1/2") Sanitary Flange
- T** 19 mm (3/4") Sanitary Flange
- N** None

### Brisip SP3 Series Capsule Filter



Capsule Format

- SP3** Brisip SP3



Inlet/Outlet

- S** 38 mm (1 1/2") Sanitary Flange



Membrane Type

- PMEA** PME 0.8/0.1 µm Nominal
- PMEB** PME 1.0/0.2 µm Nominal
- PMES** PME 1.0/0.45 µm
- PLES** PLE 0.8/0.45 µm
- PLEH** PLE 1.0/0.65 µm
- PLEL** PLE 1.5/0.8 µm
- PAFS** PAF 0.45 µm
- PAFH** PAF 0.65 µm
- PAFL** PAF 0.8 µm
- PAFP** PAF 1.0 µm
- PAFC** PAF 1.2 µm
- PEHS** PEH 0.8/0.45 µm
- PEAB** PEA 1.0/0.2 µm Nominal



Vent and Drain Valves

- P** Both using 6 mm hose barb
- X** Vent valve using quick coupling (compatible with Stäubli connector), and drain valve using 6 mm hose barb
- T** Both using quick coupling (compatible with Stäubli connector)
- V** Both using 13 mm (1/2") sanitary flange



Quantity/Package

- 1** 1 /pkg



Pharmaceutical Grade

### BriScale A50 Liquid Disc Filter



Disc Filter Format

- A50** BriScale A50



Inlet/Outlet

- BB** 6-13 mm (1/4"-1/2") Stepped Hose Barb Inlet and Outlet (No Filling Bell)
- BA** 6-13 mm (1/4"-1/2") Stepped Hose Barb Inlet and Outlet (Outlet with Filling Bell)

### Bricap SFU Series Syringe Filter (No Vent)



Syringe Filter Format

- U13** Bricap SFU13
- U25** Bricap SFU25
- U33** Bricap SFU33



Inlet/Outlet

- CP** Female luer lock inlet and male luer lock outlet

### Bricap SFV Series Syringe Filter (With Luer Vent)



Syringe Filter Format

- V25** Bricap SFV25



Inlet/Outlet

- CP** Female luer lock inlet and male luer lock outlet



Membrane Type

- HPMEA** HPME 0.8/0.1 µm Nominal
- LPMEA** LPME 0.8/0.1 µm Nominal
- HPMEB** HPME 1.0/0.2 µm Nominal
- LPMEB** LPME 1.0/0.2 µm Nominal
- HPMES** HPME 1.0/0.45 µm
- LPMES** LPME 1.0/0.45 µm
- HPLES** HPLE 0.8/0.45 µm
- LPLES** LPLE 0.8/0.45 µm
- HPLEH** HPLE 1.0/0.65 µm
- LPLEH** LPLE 1.0/0.65 µm
- HPLEL** HPLE 1.5/0.8 µm
- LPLEL** LPLE 1.5/0.8 µm
- HPEHS** HPEH 0.8/0.45 µm
- LPEHS** LPEH 0.8/0.45 µm
- HPECL** HPEC 0.8/0.45 µm
- LPECL** LPEC 0.8/0.45 µm
- HPEA** PEA 1.0/0.2 µm Nominal
- LPEA** PEA 1.0/0.2 µm Nominal



Sterilization

- A** Autoclavable
- G** Gamma Compatible
- S** Sterile
- C** Cleansteam Bag Sterile Package



Quantity/Package

- 1** 1 /pkg



Pharmaceutical Grade



Membrane Type

- PMEA** PME 0.8/0.1 µm Nominal
- PMEB** PME 1.0/0.2 µm Nominal
- PMES** PME 1.0/0.45 µm
- PLES** PLE 0.8/0.45 µm
- PLEH** PLE 1.0/0.65 µm
- PLEL** PLE 1.5/0.8 µm
- PAFS** PAF 0.45 µm
- PAFH** PAF 0.65 µm
- PAFL** PAF 0.8 µm
- PAFP** PAF 1.0 µm
- PAFC** PAF 1.2 µm
- PEHS** PEH 0.8/0.45 µm
- PEAB** PEA 1.0/0.2 µm Nominal



Sterilization

- A** Autoclavable
- G** Gamma Compatible
- S** Sterile



Quantity/Package

- 1** 1 /pkg



Pharmaceutical Grade

## Prefiltration and Bioburden Reduction Series

# Purcise PECL Filter

## Hydrophilic Filter with High Flow Rate



### Features

- Double-layer design
- Reliable retention of bacteria and particles
- Extensive chemical compatibility
- Low leachables

### Typical Applications

- Prefiltration of culture media

### Quality Control

- 100% integrity testing in manufacturing
- Each filter is fully traceable with unique serial number
- ISO 9001:2015 manufacturing facility

### Removal Rating and Effective Filtration Area

|                              | PECL(0.8/0.45 µm)   |
|------------------------------|---------------------|
| A - Standard Cartridge (10") | 0.55 m <sup>2</sup> |

### Materials of Construction

|                           |   |
|---------------------------|---|
| Membrane                  | Hydrophilic polyethersulfone (PES)                              |
| Support                   | Polypropylene (PP)  |
| Core/Cage/End Caps        | Polypropylene (PP)  |
| Cartridge End Cap Inserts | Polybutylene terephthalate (PBT)<br>(Cartridge exclusive)       |
| Cartridge End Cap O-rings | Silicone / EPDM / Fluoroelastomer /<br>PFA encapsulated O-rings |
| Capsule Housing           | Polypropylene (PP)  |
| Capsule Vent O-rings      | Silicone  |

### Maximum Differential Pressure

|                        |   |
|------------------------|---|
| A - Standard Cartridge | Forward: 0.69 MPa @ 25 °C, 0.40 MPa @ 60 °C, 0.24 MPa @ 80 °C |
|                        | Reverse: 0.30 MPa @ 25 °C, 0.10 MPa @ 80 °C                   |
| Capsule                | Forward: 0.55 MPa @ 25 °C, 0.1 MPa @ 80 °C                    |
|                        | Reverse: 0.21 MPa @ 25 °C                                     |

### Integrity Test Standards

|  |   |
|--|---|
| Standard - 10inch<br>(0.55m <sup>2</sup> ) | Bubble Point@20 °C ≥ 0.27 MPa, air, wetted with water |
|--|---|

## Sterilization

|                        |  |
|------------------------|--|
| A - Standard Cartridge | Can be steam sterilized for 30 minutes at 135 °C with 50 cycles (< 30 kPa)<br>Can be autoclaved 50 cycles for 30 minutes at 130°C  |
| Capsule                | Autoclavable capsules only: Can be autoclaved 25 cycles for 30 minutes at 130°C, (Can not be steam sterilized in-line)<br>Gamma compatible capsules: Can be sterilized by gamma irradiation at 25-45 kGy or can be autoclaved 5 cycles for 60 minutes at 126 °C. (Can not be steamed in-line)<br>Sterile capsule: Can be sterilized by gamma irradiation at 25-45 kGy<br>Cleansteam bag sterile package: Pre-sterilized with autoclave for 30 minutes at 121°C |

Notes: Gamma sterilized products cannot be re-sterilized with gamma irradiation or steam sterilization

## Flow Rates

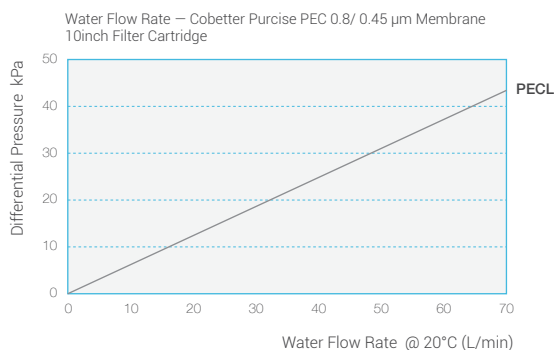







## Regulatory Compliance

- Effluent meets the USP<788> requirement of particulate matter in large volume injection.
- Component materials meet the criteria for a "Non-fiber-releasing filter" as defined in 21 CFR 210.3(b)(6).
- Retention of  $10^7$  cfu/cm<sup>2</sup> *Serratia marcescens* (ATCC 14756) according to ASTM F838
- Aqueous extraction from a cartridge contains less than 0.25EU/ml as determined by Limulus Amebocyte Lysate (LAL), meeting requirements of USP<85>.
- Components meet the requirement of USP <87> In Vitro Biological Reactivity Test.
- Components meet the criteria of the USP <88> Biological Reactivity Test for Class V-121 °C plastics.
- Components meet the FDA indirect Food Additive requirements cited in 21 CFR177-182.
- Based on the current information from our suppliers, all components used in the manufacture of this product are animal-free.



Notes: Contact Cobetter for more specification details.

**Purcise PECL Filter**  
Ordering Information



**Filter Cartridge**

|  |   |  |   |   |   |
|--|---|--|---|---|---|
|  |  |   |    |                      |  |
| Cartridge Format   | Membrane Type   | Length   | Code  | O-ring Material   | Pharmaceutical Grade  |
| <b>A</b> Standard Cartridge  | <b>PECL</b> PEC 0.8/0.45 µm   | <b>02</b> 2.5 inch<br><b>05</b> 5 inch<br><b>10</b> 10 inch<br><b>20</b> 20 inch<br><b>30</b> 30 inch<br><b>40</b> 40 inch | <b>0</b> DOE<br><b>2</b> 226 / Flat<br><b>7</b> 226 / Fin<br><b>3</b> 222 / Flat<br><b>8</b> 222 / Fin<br><b>6</b> 222 / 3-Flange bayonet / Fin | <b>S</b> Silicone<br><b>E</b> EPDM<br><b>V</b> Fluoroelastomer<br><b>P</b> FEP/PFA encapsulated O-rings |   |



**BricapC Series Capsule Filter**

|  |   |  |
|--|---|--|
|  |  |   |
| Housing Type   | Capsule Format  | Inlet/Outlet   |
| <b>Blank</b> Standard<br><b>K</b> Transparent                                    | <b>C01</b> BricapC01<br><b>C02</b> BricapC02<br><b>C03</b> BricapC03              | <b>T</b> 19 mm(3/4") Sanitary Flange<br><b>K</b> 14 mm (9/16") Sanitary Flange<br><b>F</b> 31 mm (1 1/4") Sanitary Flange<br><b>V</b> 14 mm (9/16") Hose Barb<br><b>H</b> 13 mm (1/2") Hose Barb<br><b>Y</b> 9.6 mm (3/8") Hose Barb<br><b>L</b> 3.2 mm (1/8") Hose Barb<br><b>B</b> 6-13 mm (1/4"-1/2") Stepped Hose Barb (No Filling Bell)<br><b>A</b> 6-13 mm (1/4"-1/2") Stepped Hose Barb with Filling Bell (Outlet only) |



**BricapD Series Capsule Filter**





|  |  |
|--|--|
|  |   |
| Capsule Format   | Inlet/Outlet   |
| <b>D01</b> BricapD01   | <b>B</b> 6-13 mm (1/4"-1/2") Stepped Hose Barb (No Filling Bell)<br><b>A</b> 6-13 mm (1/4"-1/2") Stepped Hose Barb with Filling Bell (Outlet only) |

**Bricap L Series Capsule Filter**

|  |  |  |
|--|--|--|
|  |   |   |
| Housing Type   | Capsule Format   | Inlet/Outlet   |
| <b>Blank</b> Standard<br><b>K</b> Transparent                                      | <b>L02</b> Bricap L02<br><b>L03</b> Bricap L03<br><b>L05</b> Bricap L05<br><b>L10</b> Bricap L10<br><b>L20</b> Bricap L20<br><b>L30</b> Bricap L30 | <b>S</b> 38 mm (1 1/2") Sanitary Flange<br><b>T</b> 19 mm (3/4") Sanitary Flange<br><b>K</b> 14 mm (9/16") Sanitary Flange<br><b>D</b> 25 mm (1") Hose Barb<br><b>M</b> 19 mm (3/4") Hose Barb<br><b>X</b> 16 mm (5/8") Hose Barb<br><b>V</b> 14 mm (9/16") Hose Barb<br><b>H</b> 13 mm (1/2") Hose Barb<br><b>Y</b> 9.6 mm (3/8") Hose Barb |

**Bricap T Series Capsule Filter**

|  |   |   |
|--|---|---|
|  |    |                              |
| Capsule Format   | Inlet/Outlet  | Gauge Port Type   |
| <b>T10</b> Bricap T10<br><b>T20</b> Bricap T20<br><b>T30</b> Bricap T30            | <b>SS</b> 38 mm (1 1/2") Sanitary Flange Inlet & Outlet<br><b>SM</b> 38 mm (1 1/2") Sanitary Flange Inlet & 19 mm (3/4") Hose Barb Outlet | <b>S</b> 38 mm (1 1/2") Sanitary Flange<br><b>T</b> 19 mm (3/4") Sanitary Flange<br><b>N</b> Without Gauge Port |

|   |   |   |   |
|---|---|---|---|
|  |                                |  |  |
| Membrane Type   | Sterilization   | Quantity/Package  | Pharmaceutical Grade  |
| <b>PECL</b> PEC 0.8/0.45 µm   | <b>A</b> Autoclavable<br><b>G</b> Gamma Compatible<br><b>S</b> Sterile<br><b>C</b> Cleansteam Bag Sterile Package | <b>1</b> 1 /pkg   | Pharmaceutical Grade  |

### Bricap HL Series Capsule Filter



Capsule Format

- HL02** Bricap HL02
- HL03** Bricap HL03
- HL05** Bricap HL05
- HL10** Bricap HL10
- HL20** Bricap HL20
- HL30** Bricap HL30



Inlet/Outlet

- S** 38 mm (1 1/2") Sanitary Flange
- T** 19 mm (3/4") Sanitary Flange
- V** 14 mm (9/16") Hose Barb
- D** 25 mm (1") Hose Barb
- H** 13 mm (1/2") Hose Barb
- Y** 9.6 mm (3/8") Hose Barb

### Bricap HT Series Capsule Filter



Capsule Format

- HT02** Bricap HT02
- HT03** Bricap HT03
- HT05** Bricap HT05
- HT10** Bricap HT10
- HT20** Bricap HT20
- HT30** Bricap HT30



Inlet/Outlet

- SS** 38 mm (1 1/2") Sanitary Flange
- SM** 38 mm (1 1/2") Sanitary Flange Inlet and 19 mm (3/4") Hose Barb Outlet



Gauge Port Type

- S** 38 mm (1 1/2") Sanitary Flange
- T** 19 mm (3/4") Sanitary Flange
- N** None

### BriScale A50 Liquid Disc Filter



Disc Filter Format

- A50** BriScale A50



Inlet/Outlet

- BB** 6-13 mm (1/4"-1/2") Stepped Hose Barb Inlet and Outlet (No Filling Bell)
- BA** 6-13 mm (1/4"-1/2") Stepped Hose Barb Inlet and Outlet (Outlet with Filling Bell)

### Bricap SFU Series Syringe Filter (No Vent)



Syringe Filter Format

- U13** Bricap SFU13
- U25** Bricap SFU25
- U33** Bricap SFU33



Inlet/Outlet

- CP** Female luer lock inlet and male luer lock outlet

### Bricap SFV Series Syringe Filter (With Luer Vent)



Syringe Filter Format

- V25** Bricap SFV25



Inlet/Outlet

- CP** Female luer lock inlet and male luer lock outlet



Membrane Type

- HPECL** HPEC 0.8/0.45 µm
- LPECL** LPEC 0.8/0.45 µm



Sterilization

- A** Autoclavable
- G** Gamma Compatible
- S** Sterile
- C** Cleansteam Bag Sterile Package



Quantity/Package

- 1** 1 /pkg



Pharmaceutical Grade



Membrane Type

- PECL** PEC 0.8/0.45 µm



Sterilization

- A** Autoclavable
- G** Gamma Compatible
- S** Sterile



Quantity/Package

- 1** 1 /pkg



Pharmaceutical Grade



## Sterilizing-Grade Filter Series

### Corevital SND Filter

#### Hydrophilic Sterilizing-Grade Filter with Low Protein Adsorption



#### Features

Low protein adsorption  
Great corrosion resistance, oxidation resistance  
Great thermo-stability  
Low leachables  
Extensive chemical compatibility

#### Typical Applications

Filtration of blood products  
Sterile filtration of antibiotic solution  
Filtration of biological reagent and vaccine

#### Quality Control

100% integrity testing in manufacturing  
Each filter is fully traceable with unique serial number  
ISO 9001:2015 manufacturing facility

#### Removal Rating and Effective Filtration Area

|                                 | SNDN(0.2 µm)        | SNDA(0.2/0.1 µm)    | SNDB(0.2/0.2 µm)    | SNDS(0.45/0.2 µm)   | SNDH(0.65/0.2 µm)   |
|---------------------------------|---------------------|---------------------|---------------------|---------------------|---------------------|
| A - Standard Cartridge (10")    | 0.55 m <sup>2</sup> | 0.55 m <sup>2</sup> | 0.55 m <sup>2</sup> | 0.55 m <sup>2</sup> | 0.55 m <sup>2</sup> |
| H - High Area Cartridge 1 (10") | 0.8 m <sup>2</sup>  | 0.8 m <sup>2</sup>  | 0.8 m <sup>2</sup>  | 0.8 m <sup>2</sup>  | 0.8 m <sup>2</sup>  |
| L - High Area Cartridge 2 (10") | 1.04 m <sup>2</sup> | 1.04 m <sup>2</sup> | 1.04 m <sup>2</sup> | 1.04 m <sup>2</sup> | 1.04 m <sup>2</sup> |

#### Materials of Construction

|                           |   |
|---------------------------|---|
| Membrane                  | Hydrophilic polyvinylidene fluoride(PVDF)                       |
| Support                   | Polypropylene (PP)  |
| Core/Cage/End Caps        | Polypropylene (PP)  |
| Cartridge End Cap Inserts | Polybutylene terephthalate (PBT)<br>(Cartridge exclusive)       |
| Cartridge End Cap O-rings | Silicone / EPDM / Fluoroelastomer /<br>PFA encapsulated O-rings |
| Capsule Housing           | Polypropylene (PP)  |
| Capsule Vent O-rings      | Silicone  |
| SP3 Capsule Port Insert   | 316L Stainless Steel  |
| SP3 Capsule Housing       | Polyetherimide (PEI)  |
| SP3 Capsule O-rings       | Silicone  |

#### Maximum Differential Pressure

|  |  |
|--|--|
| A - Standard Cartridge/<br>H - High Area Cartridge 1 | Forward: 0.69 MPa @ 25 °C, 0.40 MPa @ 60 °C, 0.24 MPa @ 80 °C<br>Reverse: 0.30 MPa @ 25 °C, 0.10 MPa @ 80 °C |
| L - High Area Cartridge 2                            | Forward: 0.55 MPa @ 25 °C, 0.40 MPa @ 60 °C, 0.24 MPa @ 80 °C<br>Reverse: 0.30 MPa @ 25 °C, 0.10 MPa @ 80 °C |
| Capsule  | Forward: 0.55 MPa @ 25 °C, 0.1 MPa @ 80 °C<br>Reverse: 0.21 MPa @ 25 °C                                      |

## Sterilization

|  |  |
|--|--|
| A - Standard Cartridge/<br>H - High Area Cartridge 1 | Can be steam sterilized for 30 minutes at 135 °C with 50 cycles (< 30 kPa)<br>Can be autoclaved 50 cycles for 30 minutes at 130°C  |
| L - High Area Cartridge 2                            | Can be steam sterilized for 30 minutes at 135 °C with 30 cycles (< 30 kPa)<br>Can be autoclaved 30 cycles for 30 minutes at 130°C  |
| Capsule  | Autoclavable capsules only: Can be autoclaved 25 cycles for 30 minutes at 130°C, (Can not be steam sterilized in-line)<br>Gamma compatible capsules: Can be sterilized by gamma irradiation at 25-45 kGy or can be autoclaved 5 cycles for 60 minutes at 126 °C. (Can not be steamed in-line)<br>Sterile capsule: Can be sterilized by gamma irradiation at 25-45 kGy<br>Cleansteam bag sterile package: Pre-sterilized with autoclave for 30 minutes at 121°C |

Notes: Gamma sterilized products cannot be re-sterilized with gamma irradiation or steam sterilization

## Integrity Test Standards

|  | SNDN   | SNDA   |
|--|--|--|
| Standard - 10inch<br>(0.55m <sup>2</sup> ) | Bubble Point@20 °C≥ 0.32 MPa, air, wetted with water<br>Air Diffusion@20 °C≤ 28 ml/min @0.28 MPa, wetted with water  | Bubble Point@20 °C≥ 0.48 MPa, air, wetted with water<br>Air Diffusion@20 °C≤ 20 ml/min @0.386 MPa, wetted with water |
| Standard Q Series<br>(0.55m <sup>2</sup> ) | Bubble Point@20 °C≥ 0.345 MPa, air, wetted with water<br>Air Diffusion@20 °C≤ 28 ml/min @0.28MPa, wetted with water  | Bubble Point@20 °C≥ 0.50 MPa, air, wetted with water<br>Air Diffusion@20 °C≤ 20 ml/min @0.386 MPa, wetted with water |
|  | SNDB   | SNDS   |
| Standard - 10inch<br>(0.55m <sup>2</sup> ) | Bubble Point@20 °C≥ 0.32 MPa, air, wetted with water<br>Air Diffusion@20 °C≤ 16 ml/min @0.28 MPa, wetted with water  | Bubble Point@20 °C≥ 0.32 MPa, air, wetted with water<br>Air Diffusion@20 °C≤ 20 ml/min @0.28 MPa, wetted with water  |
| Standard Q Series<br>(0.55m <sup>2</sup> ) | Bubble Point@20 °C≥ 0.345 MPa, air, wetted with water<br>Air Diffusion@20 °C≤ 16 ml/min @0.28 MPa, wetted with water | Bubble Point@20 °C≥ 0.345 MPa, air, wetted with water<br>Air Diffusion@20 °C≤ 20 ml/min @0.28 MPa, wetted with water |
|  | SNDH   |  |
| Standard - 10inch<br>(0.55m <sup>2</sup> ) | Bubble Point@20 °C≥ 0.32 MPa, air, wetted with water<br>Air Diffusion@20 °C≤ 20 ml/min @0.28 MPa, wetted with water  |  |
| Standard Q Series<br>(0.55m <sup>2</sup> ) | Bubble Point@20 °C≥ 0.345 MPa, air, wetted with water<br>Air Diffusion@20 °C≤ 20 ml/min @0.28 MPa, wetted with water |  |

## Flow Rates

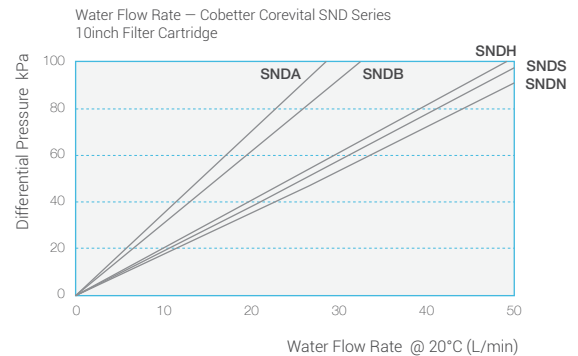
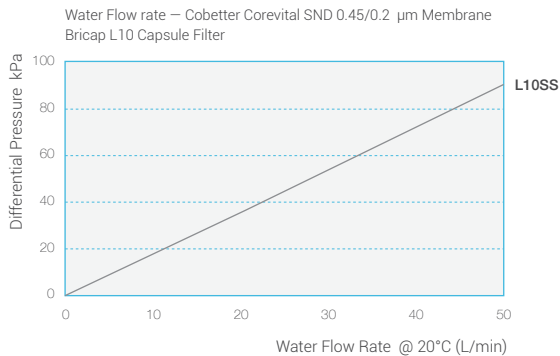
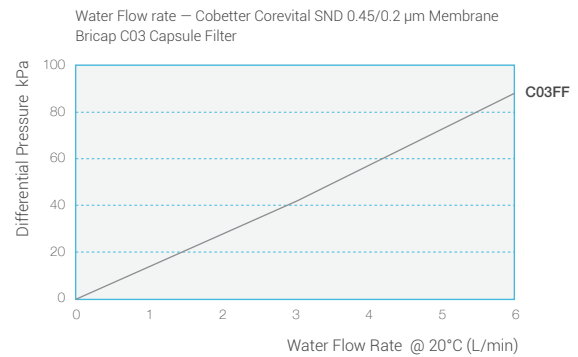
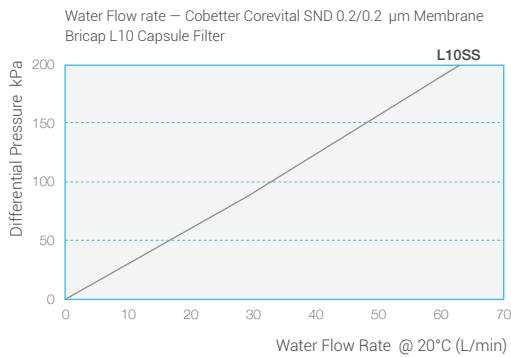
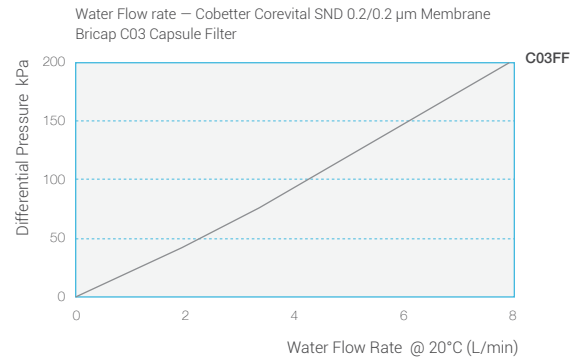
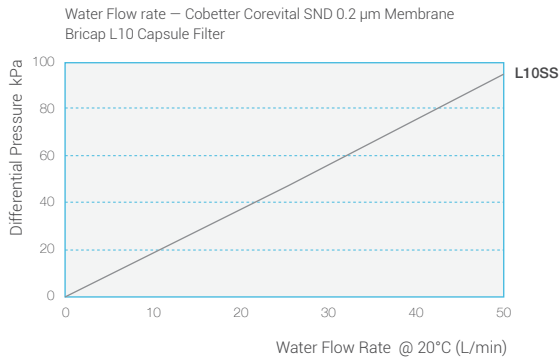

## Regulatory Compliance

- Effluent meets the USP<788> requirement of particulate matter in large volume injection.
- Component materials meet the criteria for a "Non-fiber-releasing filter" as defined in 21 CFR 210.3(b)(6).
- Retention of  $10^7$  cfu/cm<sup>2</sup> *Brevundimonas diminuta* (ATCC 19146) according to ASTM F838
- Aqueous extraction from a cartridge contains less than 0.25EU/ml as determined by Limulus Amebocyte Lysate (LAL), meeting requirements of USP<85>.
- Components meet the requirement of USP <87> In Vitro Biological Reactivity Test.
- Components meet the criteria of the USP <88> Biological Reactivity Test for Class V-121 °C plastics.
- Components meet the FDA indirect Food Additive requirements cited in 21 CFR177-182.
- Based on the current information from our suppliers, all components used in the manufacture of this product are animal-free.

Notes: Contact Cobetter for more specification details.

## Sterilizing-Grade Filter Series

# Corevital SMD Filter

## Hydrophilic Sterilizing-Grade Filter with High Throughput and Low Protein Adsorption



### Features

High throughput  
Low protein adsorption  
Reliable retention of bacteria and particles

### Typical Applications

Buffer filtration  
Pre-column/ultra-filtration protection  
Filtration of intermediate products/stock solutions  
Filtration of serum and blood products, sterile filtration of terminal products  
Filtration of colloidal or viscous liquids

### Quality Control

100% integrity testing in manufacturing  
Each filter is fully traceable with unique serial number  
ISO 9001:2015 manufacturing facility

### Removal Rating and Effective Filtration Area

|                                 | SMDN(0.2 μm)        | SMDA(0.2/0.1 μm)    | SMDB(0.2/0.2 μm)    | SMDS(0.45/0.2 μm)   | SMDH(0.65/0.2 μm)   |
|---------------------------------|---------------------|---------------------|---------------------|---------------------|---------------------|
| A - Standard Cartridge (10")    | 0.55 m <sup>2</sup> | 0.55 m <sup>2</sup> | 0.55 m <sup>2</sup> | 0.55 m <sup>2</sup> | 0.55 m <sup>2</sup> |
| H - High Area Cartridge 1 (10") | 0.8 m <sup>2</sup>  | 0.8 m <sup>2</sup>  | 0.8 m <sup>2</sup>  | 0.8 m <sup>2</sup>  | 0.8 m <sup>2</sup>  |
| L - High Area Cartridge 2 (10") | 1.04 m <sup>2</sup> | 1.04 m <sup>2</sup> | 1.04 m <sup>2</sup> | 1.04 m <sup>2</sup> | 1.04 m <sup>2</sup> |

### Materials of Construction

|                           |   |
|---------------------------|---|
| Membrane                  | Hydrophilic polyvinylidene fluoride(PVDF)                       |
| Support                   | Polypropylene (PP)  |
| Core/Cage/End Caps        | Polypropylene (PP)  |
| Cartridge End Cap Inserts | Polybutylene terephthalate (PBT)<br>(Cartridge exclusive)       |
| Cartridge End Cap O-rings | Silicone / EPDM / Fluoroelastomer /<br>PFA encapsulated O-rings |
| Capsule Housing           | Polypropylene (PP)  |
| Capsule Vent O-rings      | Silicone  |
| SP3 Capsule Port Insert   | 316L Stainless Steel  |
| SP3 Capsule Housing       | Polyetherimide (PEI)  |
| SP3 Capsule O-rings       | Silicone  |

### Maximum Differential Pressure

|  |  |
|--|--|
| A - Standard Cartridge/<br>H - High Area Cartridge 1 | Forward: 0.69 MPa @ 25 °C, 0.40 MPa @ 60 °C, 0.24 MPa @ 80 °C<br>Reverse: 0.30 MPa @ 25 °C, 0.10 MPa @ 80 °C |
| L - High Area Cartridge 2                            | Forward: 0.55 MPa @ 25 °C, 0.40 MPa @ 60 °C, 0.24 MPa @ 80 °C<br>Reverse: 0.30 MPa @ 25 °C, 0.10 MPa @ 80 °C |
| Capsule  | Forward: 0.55 MPa @ 25 °C, 0.1MPa @ 80 °C<br>Reverse: 0.21 MPa @ 25 °C                                       |

## Sterilization

|  |  |
|--|--|
| A - Standard Cartridge/<br>H - High Area Cartridge 1 | Can be steam sterilized for 30 minutes at 135 °C with 50 cycles (< 30 kPa)<br>Can be autoclaved 50 cycles for 30 minutes at 130°C  |
| L - High Area Cartridge 2                            | Can be steam sterilized for 30 minutes at 135 °C with 30 cycles (< 30 kPa)<br>Can be autoclaved 30 cycles for 30 minutes at 130°C  |
| Capsule  | Autoclavable capsules only: Can be autoclaved 25 cycles for 30 minutes at 130°C, (Can not be steam sterilized in-line)<br>Gamma compatible capsules: Can be sterilized by gamma irradiation at 25-45 kGy or can be autoclaved 5 cycles for 60 minutes at 126 °C. (Can not be steamed in-line)<br>Sterile capsule: Can be sterilized by gamma irradiation at 25-45 kGy<br>Cleansteam bag sterile package: Pre-sterilized with autoclave for 30 minutes at 121°C |

Notes: Gamma sterilized products cannot be re-sterilized with gamma irradiation or steam sterilization

## Integrity Test Standards

### SMDN / SMDB / SMDS / SMDH

|  |   |
|--|---|
| Standard - 10inch<br>(0.55m <sup>2</sup> ) | Bubble Point@20 °C ≥ 0.32 MPa, air, wetted with water<br>Air Diffusion@20 °C ≤ 20 ml/min @0.28 MPa, wetted with water |
| Standard Q Series<br>(0.55m <sup>2</sup> ) | Bubble Point@20 °C ≥ 0.345 MPa, air, wetted with water<br>Air Diffusion@20 °C ≤ 20 ml/min @0.28MPa, wetted with water |

### SMDA

|  |  |
|--|--|
| Standard - 10inch<br>(0.55m <sup>2</sup> ) | Bubble Point@20 °C ≥ 0.48 MPa, air, wetted with water<br>Air Diffusion@20 °C ≤ 20 ml/min @0.386 MPa, wetted with water |
| Standard Q Series<br>(0.55m <sup>2</sup> ) | Bubble Point@20 °C ≥ 0.50 MPa, air, wetted with water<br>Air Diffusion@20 °C ≤ 20 ml/min @0.386 MPa, wetted with water |

## Flow Rates

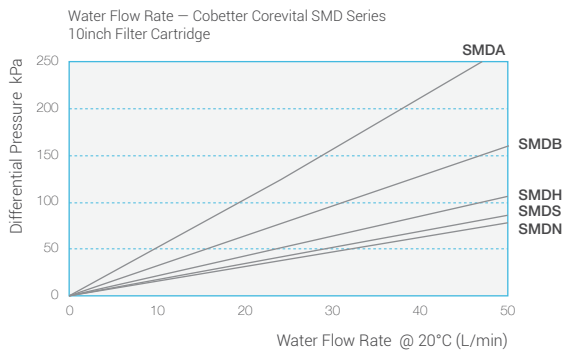
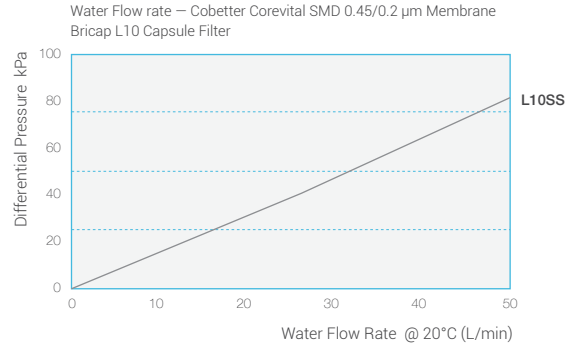
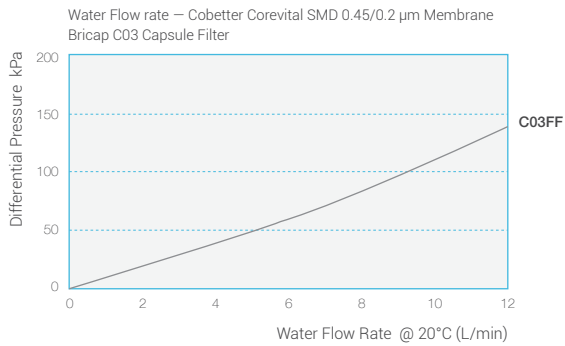
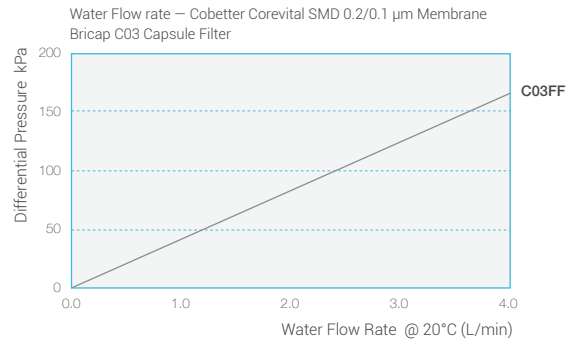
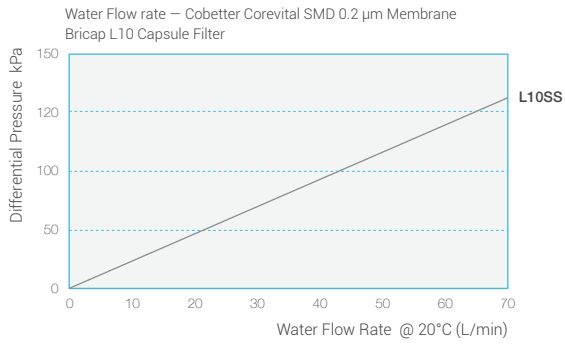

## Regulatory Compliance

- Effluent meets the USP<788> requirement of particulate matter in large volume injection.
- Component materials meet the criteria for a "Non-fiber-releasing filter" as defined in 21 CFR 210.3(b)(6).
- Retention of  $10^7$  cfu/cm<sup>2</sup> *Brevundimonas diminuta* (ATCC 19146) according to ASTM F838
- Aqueous extraction from a cartridge contains less than 0.25EU/ml as determined by Limulus Amebocyte Lysate (LAL), meeting requirements of USP<85>.
- Components meet the requirement of USP <87> In Vitro Biological Reactivity Test.
- Components meet the criteria of the USP <88> Biological Reactivity Test for Class V-121 °C plastics.
- Components meet the FDA indirect Food Additive requirements cited in 21 CFR177-182.
- Based on the current information from our suppliers, all components used in the manufacture of this product are animal-free.

Notes: Contact Cobetter for more specification details.

## Corevital SND/SMD

### Ordering Information

#### Filter Cartridge



Cartridge Format

- A** Standard Cartridge
- H** H - High Area Cartridge(0.69-0.8m<sup>2</sup>)
- L** L - High Area Cartridge(1.0-1.2m<sup>2</sup>)



Membrane Type

- SNDN** SND 0.2 µm
- SNDA** SND 0.2/0.1 µm
- SNDB** SND 0.2/0.2 µm
- SNDS** SND 0.45/0.2 µm
- SNDH** SND 0.65/0.2 µm
- SMDN** SMD 0.2 µm
- SMDA** SMD 0.2/0.1 µm
- SMDB** SMD 0.2/0.2 µm
- SMDS** SMD 0.45/0.2 µm
- SMDH** SMD 0.65/0.2 µm



Length

- 02** 2.5 inch
- 05** 5 inch
- 10** 10 inch
- 20** 20 inch
- 30** 30 inch
- 40** 40 inch



Code

- 0** DOE
- 2** 226 / Flat
- 7** 226 / Fin
- 3** 222 / Flat
- 8** 222 / Fin
- 6** 222 / 3-Flange bayonet / Fin



O-ring Material

- S** Silicone
- E** EPDM
- V** Fluoroelastomer
- P** FEP/PFA encapsulated O-rings



Category

- Blank** Standard
- Q**



Pharmaceutical Grade

#### Bricap C Series Capsule Filter



Housing Type

- Blank** Standard
- K** Transparent



Capsule Format

- C01** BricapC01
- C02** BricapC02
- C03** Bricap C03



Inlet/Outlet

- T** 19 mm (3/4") Sanitary Flange
- K** 14 mm (9/16") Sanitary Flange
- F** 31 mm (1 1/4") Sanitary Flange
- V** 14 mm (9/16") Hose Barb
- H** 13 mm (1/2") Hose Barb
- Y** 9.6 mm (3/8") Hose Barb
- L** 3.2 mm (1/8") Hose Barb
- B** 6-13 mm (1/4"-1/2") Stepped Hose Barb (No Filling Bell)
- A** 6-13 mm (1/4"-1/2") Stepped Hose Barb with Filling Bell (Outlet only)

#### Bricap D Series Capsule Filter



Capsule Format

- D01** BricapD01



Inlet/Outlet

- B** 6-13 mm (1/4"-1/2") Stepped Hose Barb (No Filling Bell)
- A** 6-13 mm (1/4"-1/2") Stepped Hose Barb with Filling Bell (Outlet only)

#### Bricap L Series Capsule Filter



Housing Type

- Blank** Standard
- K** Transparent



Capsule Format

- L02** Bricap L02
- L03** Bricap L03
- L05** Bricap L05
- L10** Bricap L10
- L20** Bricap L20
- L30** Bricap L30



Inlet/Outlet

- S** 38 mm (1 1/2") Sanitary Flange
- T** 19 mm (3/4") Sanitary Flange
- K** 14 mm (9/16") Sanitary Flange
- D** 25 mm (1") Hose Barb
- M** 19 mm (3/4") Hose Barb
- X** 16 mm (5/8") Hose Barb
- V** 14 mm (9/16") Hose Barb
- H** 13 mm (1/2") Hose Barb
- Y** 9.6 mm (3/8") Hose Barb

#### Bricap T Series Capsule Filter



Capsule Format

- T10** Bricap T10
- T20** Bricap T20
- T30** Bricap T30



Inlet/Outlet

- SS** 38 mm (1 1/2") Sanitary Flange Inlet & Outlet
- SM** 38 mm (1 1/2") Sanitary Flange Inlet & 19 mm (3/4") Hose Barb Outlet



Gauge Port Type

- S** 38 mm (1 1/2") Sanitary Flange
- T** 19 mm (3/4") Sanitary Flange
- N** Without Gauge Port

|  |   |   |   |  |
|--|---|---|---|--|
|  |   |   |   |  |
| Membrane Type  | Sterilization   | Quantity/Package  | Category  | Pharmaceutical Grade   |
| <ul style="list-style-type: none"> <li><b>SNDN</b> SND 0.2 µm</li> <li><b>SNDA</b> SND 0.2/0.1 µm</li> <li><b>SNDB</b> SND 0.2/0.2 µm</li> <li><b>SNDS</b> SND 0.45/0.2 µm</li> <li><b>SNDH</b> SND 0.65/0.2 µm</li> <li><b>SMDN</b> SMD 0.2 µm</li> <li><b>SMDA</b> SMD 0.2/0.1 µm</li> <li><b>SMDB</b> SMD 0.2/0.2 µm</li> <li><b>SMDS</b> SMD 0.45/0.2 µm</li> <li><b>SMDH</b> SMD 0.65/0.2 µm</li> </ul> | <ul style="list-style-type: none"> <li><b>A</b> Autoclavable</li> <li><b>G</b> Gamma Compatible</li> <li><b>S</b> Sterile</li> <li><b>C</b> Cleansteam Bag Sterile Package</li> </ul> | <ul style="list-style-type: none"> <li><b>1</b> 1 /pkg</li> </ul> | <ul style="list-style-type: none"> <li><b>Blank</b> Standard</li> <li><b>Q</b></li> </ul> | <ul style="list-style-type: none"> <li>Pharmaceutical Grade</li> </ul> |



### Bricap HL Series Capsule Filter



Capsule Format

- HL02** Bricap HL02
- HL03** Bricap HL03
- HL05** Bricap HL05
- HL10** Bricap HL10
- HL20** Bricap HL20
- HL30** Bricap HL30



Inlet/Outlet

- S** 38 mm (1 1/2") Sanitary Flange
- T** 19 mm (3/4") Sanitary Flange
- V** 14 mm (9/16") Hose Barb
- D** 25 mm (1") Hose Barb
- H** 13 mm (1/2") Hose Barb
- Y** 9.6 mm (3/8") Hose Barb

### Bricap HT Series Capsule Filter



Capsule Format

- HT02** Bricap HT02
- HT03** Bricap HT03
- HT05** Bricap HT05
- HT10** Bricap HT10
- HT20** Bricap HT20
- HT30** Bricap HT30



Inlet/Outlet

- SS** 38 mm (1 1/2") Sanitary Flange
- SM** 38 mm (1 1/2") Sanitary Flange Inlet and 19 mm (3/4") Hose Barb Outlet



Gauge Port Type

- S** 38 mm (1 1/2") Sanitary Flange
- T** 19 mm (3/4") Sanitary Flange
- N** None

### Brisip SP3 Series Capsule Filter



Capsule Format

- SP3** Brisip SP3



Inlet/Outlet

- S** 38 mm (1 1/2") Sanitary Flange



Membrane Type

- SNDN** SND 0.2 µm
- SNDA** SND 0.2/0.1 µm
- SNDB** SND 0.2/0.2 µm
- SNDS** SND 0.45/0.2 µm
- SNDH** SND 0.65/0.2 µm
- SMDN** SMD 0.2 µm
- SMDA** SMD 0.2/0.1 µm
- SMDB** SMD 0.2/0.2 µm
- SMDS** SMD 0.45/0.2 µm
- SMDH** SMD 0.65/0.2 µm



Vent and Drain Valves

- P** Both using 6 mm hose barb
- X** Vent valve using quick coupling (compatible with Stäubli connector), and drain valve using 6 mm hose barb
- T** Both using quick coupling (compatible with Stäubli connector)
- V** Both using 13 mm (1/2") sanitary flange



Quantity/Package

- 1** 1 /pkg



Category

- Blank Q** Standard Pharmaceutical Grade



### BriScale A50 Liquid Disc Filter



Disc Filter Format

- A50** BriScale A50



Inlet/Outlet

- BB** 6-13 mm (1/4"-1/2") Stepped Hose Barb Inlet and Outlet (No Filling Bell)
- BA** 6-13 mm (1/4"-1/2") Stepped Hose Barb Inlet and Outlet (Outlet with Filling Bell)

### Bricap SFU Series Syringe Filter (No Vent)



Syringe Filter Format

- U13** Bricap SFU13
- U25** Bricap SFU25
- U33** Bricap SFU33



Inlet/Outlet

- CP** Female luer lock inlet and male luer lock outlet

### Bricap SFV Series Syringe Filter (With Luer Vent)



Syringe Filter Format

- V25** Bricap SFV25



Inlet/Outlet

- CP** Female luer lock inlet and male luer lock outlet



Membrane Type

- HSNDN** HSND 0.2 µm
- LSNDN** LSND 0.2 µm
- HSNDA** HSND 0.2/0.1 µm
- LSNDA** LSND 0.2/0.1 µm
- HSNDB** HSND 0.2/0.2 µm
- LSNDB** LSND 0.2/0.2 µm
- HSNDS** HSND 0.45/0.2 µm
- LSNDS** LSND 0.45/0.2 µm
- HSNDH** HSND 0.65/0.2 µm
- LSNDH** LSND 0.65/0.2 µm
- HSMDN** HSMD 0.2 µm
- LSMDN** LSMD 0.2 µm
- HSMDA** HSMD 0.2/0.1 µm
- LSMDA** LSMD 0.2/0.1 µm
- HSMDB** HSMD 0.2/0.2 µm
- LSMDB** LSMD 0.2/0.2 µm
- HSMDS** HSMD 0.45/0.2 µm
- LSMDS** LSMD 0.45/0.2 µm
- HSMDH** HSMD 0.65/0.2 µm
- LSMDH** LSMD 0.65/0.2 µm



Sterilization

- A** Autoclavable
- G** Gamma Compatible
- S** Sterile
- C** Cleansteam Bag Sterile Package



Quantity/Package

- 1** 1 /pkg



Category

- Blank Q** Standard Pharmaceutical Grade



Membrane Type

- SNDN** SND 0.2 µm
- SNDA** SND 0.2/0.1 µm
- SNDB** SND 0.2/0.2 µm
- SNDS** SND 0.45/0.2 µm
- SNDH** SND 0.65/0.2 µm
- SMDN** SMD 0.2 µm
- SMDA** SMD 0.2/0.1 µm
- SMDB** SMD 0.2/0.2 µm
- SMDS** SMD 0.45/0.2 µm
- SMDH** SMD 0.65/0.2 µm



Sterilization

- A** Autoclavable
- G** Gamma Compatible
- S** Sterile



Quantity/Package

- 1** 1 /pkg



Category

- Blank Q** Standard Pharmaceutical Grade



## Sterilizing-Grade Filter Series

### Corevital SVLB Filter

Hydrophilic Sterilizing-Grade Filter with High Throughput and Low Protein Adsorption



#### Features

High flow rate, high loading  
Low leachables  
Low adsorption

#### Typical Applications

Buffer filtration  
Pre-column/ultra-filtration protection  
Filtration of intermediate products/stock solutions  
Filtration of serum and blood products, sterile filtration of terminal products  
Filtration of colloidal or viscous liquids

#### Quality Control

100% integrity testing in manufacturing  
Each filter is fully traceable with unique serial number  
ISO 9001:2015 manufacturing facility

#### Removal Rating and Effective Filtration Area

|                              | SVLB(0.2 $\mu\text{m}$ ) |
|------------------------------|--------------------------|
| A - Standard Cartridge (10") | 0.73 m <sup>2</sup>      |

#### Materials of Construction

|                           |   |
|---------------------------|---|
| Membrane                  | Hydrophilic polyvinylidene fluoride(PVDF)                       |
| Support                   | Polypropylene (PP)  |
| Core/Cage/End Caps        | Polypropylene (PP)  |
| Cartridge End Cap Inserts | Polybutylene terephthalate (PBT)<br>(Cartridge exclusive)       |
| Cartridge End Cap O-rings | Silicone / EPDM / Fluoroelastomer /<br>PFA encapsulated O-rings |
| Capsule Housing           | Polypropylene (PP)  |
| Capsule Vent O-rings      | Silicone  |

#### Maximum Differential Pressure

|                        |   |
|------------------------|---|
| A - Standard Cartridge | Forward: 0.69 MPa @ 25 °C, 0.40 MPa @ 60 °C, 0.24 MPa @ 80 °C |
|                        | Reverse: 0.30 MPa @ 25 °C, 0.10 MPa @ 80 °C                   |
| Capsule                | Forward: 0.55 MPa @ 25 °C, 0.1MPa @ 80 °C                     |
|                        | Reverse: 0.21 MPa @ 25 °C                                     |

#### Integrity Test Standards

|  |   |
|--|---|
| Standard - 10inch<br>(0.55m <sup>2</sup> ) | Bubble Point@20 °C $\geq$ 0.365 MPa, air, wetted with water         |
|  | Air Diffusion@20 °C $\leq$ 26.5 ml/min @0.28 MPa, wetted with water |

## Sterilization

|                        |  |
|------------------------|--|
| A - Standard Cartridge | Can be steam sterilized for 30 minutes at 135 °C with 50 cycles (< 30 kPa)<br>Can be autoclaved 50 cycles for 30 minutes at 130°C  |
| Capsule                | Autoclavable capsules only: Can be autoclaved 25 cycles for 30 minutes at 130°C, (Can not be steam sterilized in-line)<br>Gamma compatible capsules: Can be sterilized by gamma irradiation at 25-45 kGy or can be autoclaved 5 cycles for 60 minutes at 126 °C. (Can not be steamed in-line)<br>Sterile capsule: Can be sterilized by gamma irradiation at 25-45 kGy<br>Cleansteam bag sterile package: Pre-sterilized with autoclave for 30 minutes at 121°C |

Notes: Gamma sterilized products cannot be re-sterilized with gamma irradiation or steam sterilization

## Flow Rates

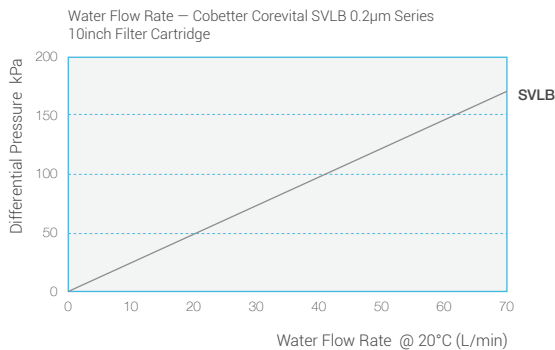

## Regulatory Compliance







- Effluent meets the USP<788> requirement of particulate matter in large volume injection.
- Component materials meet the criteria for a "Non-fiber-releasing filter" as defined in 21 CFR 210.3(b)(6).
- Retention of  $10^7$  cfu/cm<sup>2</sup> *Brevundimonas diminuta* (ATCC 19146) according to ASTM F838
- Aqueous extraction from a cartridge contains less than 0.25EU/ml as determined by Limulus Amebocyte Lysate (LAL), meeting requirements of USP<85>.
- Components meet the requirement of USP <87> In Vitro Biological Reactivity Test.
- Components meet the criteria of the USP <88> Biological Reactivity Test for Class V-121 °C plastics.
- Components meet the FDA indirect Food Additive requirements cited in 21 CFR177-182.
- Based on the current information from our suppliers, all components used in the manufacture of this product are animal-free.

Notes: Contact Cobetter for more specification details.







## Corevital SVLB

### Ordering Information



#### Filter Cartridge

|  |   |  |   |   |   |
|--|---|--|---|---|---|
|  |  |   |    |                      |  |
| Cartridge Format   | Membrane Type   | Length   | Code  | O-ring Material   | Pharmaceutical Grade  |
| <b>A</b> Standard Cartridge  | <b>SVLB</b> SVL 0.2 µm  | <b>02</b> 2.5 inch<br><b>05</b> 5 inch<br><b>10</b> 10 inch<br><b>20</b> 20 inch<br><b>30</b> 30 inch<br><b>40</b> 40 inch | <b>0</b> DOE<br><b>2</b> 226 / Flat<br><b>7</b> 226 / Fin<br><b>3</b> 222 / Flat<br><b>8</b> 222 / Fin<br><b>6</b> 222 / 3-Flange bayonet / Fin | <b>S</b> Silicone<br><b>E</b> EPDM<br><b>V</b> Fluoroelastomer<br><b>P</b> FEP/PFA encapsulated O-rings |   |



#### Bricap C Series Capsule Filter

|  |   |   |   |   |   |   |
|--|---|---|---|---|---|---|
|  |  |    |  |                                |  |  |
| Housing Type   | Capsule Format  | Inlet/Outlet  | Membrane Type   | Sterilization   | Quantity/Package  | Pharmaceutical Grade  |
| <b>Blank</b> Standard<br><b>K</b> Transparent                                    | <b>C01</b> Bricap C01<br><b>C02</b> Bricap C02<br><b>C03</b> Bricap C03           | <b>T</b> 19 mm (3/4") Sanitary Flange<br><b>K</b> 14 mm (9/16") Sanitary Flange<br><b>F</b> 31 mm (1 1/4") Sanitary Flange<br><b>V</b> 14 mm (9/16") Hose Barb<br><b>H</b> 13 mm (1/2") Hose Barb<br><b>Y</b> 9.6 mm (3/8") Hose Barb<br><b>L</b> 3.2 mm (1/8") Hose Barb<br><b>B</b> 6-13 mm (1/4"-1/2") Stepped Hose Barb (No Filling Bell)<br><b>A</b> 6-13 mm (1/4"-1/2") Stepped Hose Barb with Filling Bell (Outlet only) | <b>SVLB</b> SVL 0.2 µm  | <b>A</b> Autoclavable<br><b>G</b> Gamma Compatible<br><b>S</b> Sterile<br><b>C</b> Cleansteam Bag Sterile Package | <b>1</b> 1 /pkg   |   |

#### Bricap L Series Capsule Filter

|  |  |  |
|--|--|--|
|  |   |   |
| Housing Type   | Capsule Format   | Inlet/Outlet   |
| <b>Blank</b> Standard<br><b>K</b> Transparent                                      | <b>L02</b> Bricap L02<br><b>L03</b> Bricap L03<br><b>L05</b> Bricap L05<br><b>L10</b> Bricap L10<br><b>L20</b> Bricap L20<br><b>L30</b> Bricap L30 | <b>S</b> 38 mm (1 1/2") Sanitary Flange<br><b>T</b> 19 mm (3/4") Sanitary Flange<br><b>K</b> 14 mm (9/16") Sanitary Flange<br><b>D</b> 25 mm (1") Hose Barb<br><b>M</b> 19 mm (3/4") Hose Barb<br><b>X</b> 16 mm (5/8") Hose Barb<br><b>V</b> 14 mm (9/16") Hose Barb<br><b>H</b> 13 mm (1/2") Hose Barb<br><b>Y</b> 9.6 mm (3/8") Hose Barb |

#### Bricap T Series Capsule Filter

|  |   |   |
|--|---|---|
|  |    |                              |
| Capsule Format   | Inlet/Outlet  | Gauge Port Type   |
| <b>T10</b> Bricap T10<br><b>T20</b> Bricap T20<br><b>T30</b> Bricap T30            | <b>SS</b> 38 mm (1 1/2") Sanitary Flange Inlet & Outlet<br><b>SM</b> 38 mm (1 1/2") Sanitary Flange Inlet & 19 mm (3/4") Hose Barb Outlet | <b>S</b> 38 mm (1 1/2") Sanitary Flange<br><b>T</b> 19 mm (3/4") Sanitary Flange<br><b>N</b> Without Gauge Port |

### BriScale A50 Liquid Disc Filter



Disc Filter Format

**A50** BriScale A50



Inlet/Outlet

**BB** 6-13 mm (1/4"-1/2") Stepped Hose Barb Inlet and Outlet (No Filling Bell)

**BA** 6-13 mm (1/4"-1/2") Stepped Hose Barb Inlet and Outlet (Outlet with Filling Bell)

### Bricap SFU Series Syringe Filter (No Vent)



Syringe Filter Format

**U13** Bricap SFU13  
**U25** Bricap SFU25  
**U33** Bricap SFU33



Inlet/Outlet

**CP** Female luer lock inlet and male luer lock outlet

### Bricap SFV Series Syringe Filter (With Luer Vent)



Syringe Filter Format

**V25** Bricap SFV25



Inlet/Outlet

**CP** Female luer lock inlet and male luer lock outlet



Membrane Type

**SVLB** SVL 0.2 µm



Sterilization

**A** Autoclavable  
**G** Gamma Compatible  
**S** Sterile



Quantity/  
Package

**1** 1 /pkg



Category

**Blank** Standard  
**Q**



Pharmaceutical  
Grade

## Prefiltration and Bioburden Reduction Series

# Corevital PMDS Filter

## Hydrophilic Filter with Low Protein Adsorption



### Features

Double-layer design, high throughput  
 Low protein adsorption  
 Reliable retention of bacteria and particles

### Typical Applications

Buffer filtration  
 Bioburden reduction  
 Pre-column/ultrafiltration protection  
 Protective filtration before sterile filtration

### Quality Control

100% integrity testing in manufacturing  
 Each filter is fully traceable with unique serial number  
 ISO 9001:2015 manufacturing facility

### Removal Rating and Effective Filtration Area

|                                 | PMDS(1.0/0.45 µm)   |
|---------------------------------|---------------------|
| A - Standard Cartridge (10")    | 0.55 m <sup>2</sup> |
| H - High Area Cartridge 1 (10") | 0.8 m <sup>2</sup>  |
| L - High Area Cartridge 2 (10") | 1.04 m <sup>2</sup> |

### Materials of Construction

|                           |   |
|---------------------------|---|
| Membrane                  | Hydrophilic polyvinylidene fluoride(PVDF)                       |
| Support                   | Polypropylene (PP)  |
| Core/Cage/End Caps        | Polypropylene (PP)  |
| Cartridge End Cap Inserts | Polybutylene terephthalate (PBT)<br>(Cartridge exclusive)       |
| Cartridge End Cap O-rings | Silicone / EPDM / Fluoroelastomer /<br>PFA encapsulated O-rings |
| Capsule Housing           | Polypropylene (PP)  |
| Capsule Vent O-rings      | Silicone  |
| SP3 Capsule Port Insert   | 316L Stainless Steel  |
| SP3 Capsule Housing       | Polyetherimide (PEI)  |
| SP3 Capsule O-rings       | Silicone  |

### Maximum Differential Pressure

|                           |  |
|---------------------------|--|
| A - Standard Cartridge/   | Forward: 0.69 MPa @ 25 °C, 0.40 MPa @ 60 °C, 0.24 MPa @ 80 °C  |
| H - High Area Cartridge 1 | Reverse: 0.30 MPa @ 25 °C, 0.10 MPa @ 80 °C  |
| L - High Area Cartridge 2 | Forward: 0.55 MPa @ 25 °C, 0.40 MPa @ 60 °C, 0.24 MPa @ 80 °C<br>Reverse: 0.30 MPa @ 25 °C, 0.10 MPa @ 80 °C |
| Capsule                   | Forward: 0.55 MPa @ 25 °C, 0.1 MPa @ 80 °C<br>Reverse: 0.21 MPa @ 25 °C                                      |

### Integrity Test Standards

|  |   |
|--|---|
| Standard - 10inch<br>(0.55m <sup>2</sup> ) | Bubble Point @20 °C ≥ 0.18 MPa, air, wetted with water<br>Air Diffusion @20 °C ≤ 15 ml/min @0.15 MPa, wetted with water |
|--|---|

## Sterilization

|  |   |
|--|---|
| A - Standard Cartridge/<br>H - High Area Cartridge 1 | Can be steam sterilized for 30 minutes at 135 °C with 50 cycles (< 30 kPa)<br>Can be autoclaved 50 cycles for 30 minutes at 130°C                                   |
| L - High Area Cartridge 2                            | Can be steam sterilized for 30 minutes at 135 °C with 30 cycles (< 30 kPa)<br>Can be autoclaved 30 cycles for 30 minutes at 130°C                                   |
| Capsule  | Autoclavable capsules only : Can be autoclaved 25 cycles for 30 minutes at 130°C, (Can not be steam sterilized in-line)   |
|  | Gamma compatible capsules: Can be sterilized by gamma irradiation at 25-45 kGy or can be autoclaved 5 cycles for 60 minutes at 126 °C. (Can not be steamed in-line) |
|  | Sterile capsule: Can be sterilized by gamma irradiation at 25-45 kGy  |
|  | Cleansteam bag sterile package: Pre-sterilized with autoclave for 30 minutes at 121°C   |

Notes: Gamma sterilized products cannot be re-sterilized with gamma irradiation or steam sterilization

## Flow Rates

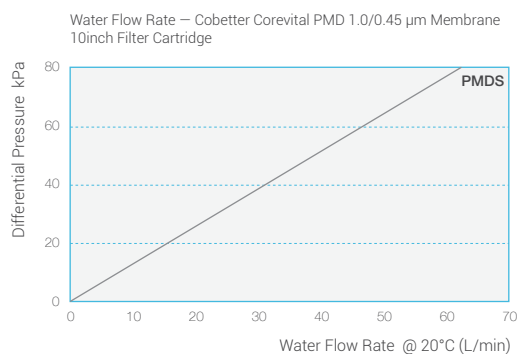
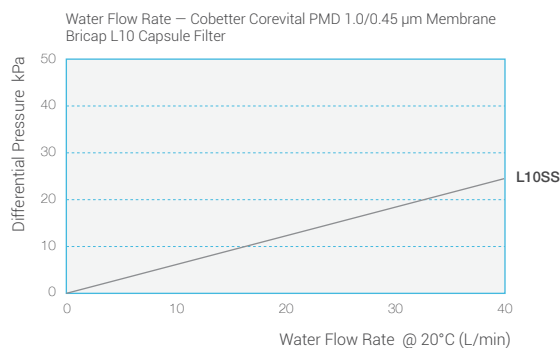
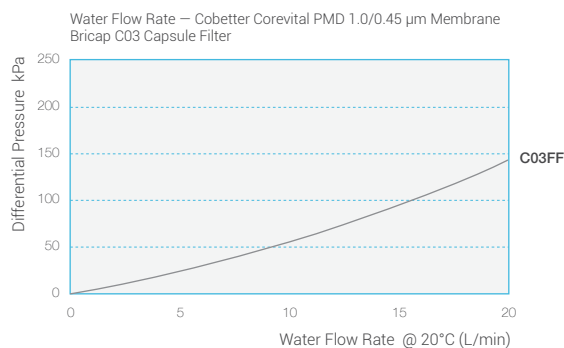

## Regulatory Compliance

- Effluent meets the USP<788> requirement of particulate matter in large volume injection.
- Component materials meet the criteria for a "Non-fiber-releasing filter" as defined in 21 CFR 210.3(b)(6).
- Retention of  $10^7$  cfu/cm<sup>2</sup> *Serratia marcescens* (ATCC 14756) according to ASTM F838
- Aqueous extraction from a cartridge contains less than 0.25EU/ml as determined by Limulus Amebocyte Lysate (LAL), meeting requirements of USP<85>.
- Components meet the requirement of USP <87> In Vitro Biological Reactivity Test.
- Components meet the criteria of the USP <88> Biological Reactivity Test for Class V-121 °C plastics.
- Components meet the FDA indirect Food Additive requirements cited in 21 CFR 177-182.
- Based on the current information from our suppliers, all components used in the manufacture of this product are animal-free.

Notes: Contact Cobetter for more specification details.



## Prefiltration and Bioburden Reduction Series

# Corevital PDFS Filter

## Hydrophilic Filter with Low Protein Adsorption



### Features

High throughput  
Low protein adsorption  
Reliable retention of bacteria and particles

### Typical Applications

Bacterial reduction of 4-6 LRV  
Buffer filtration, bioburden reduction  
Pre-column/ultra filtration protection  
Protective filtration before sterilization filtration

### Quality Control

100% integrity testing in manufacturing  
Each filter is fully traceable with unique serial number  
ISO 9001:2015 manufacturing facility

### Removal Rating and Effective Filtration Area

|                                 | PDFS(0.45 µm)       |
|---------------------------------|---------------------|
| A - Standard Cartridge (10")    | 0.55 m <sup>2</sup> |
| H - High Area Cartridge 1 (10") | 0.8 m <sup>2</sup>  |
| L - High Area Cartridge 2 (10") | 1.04 m <sup>2</sup> |

### Materials of Construction

|                           |   |
|---------------------------|---|
| Membrane                  | Hydrophilic polyvinylidene fluoride(PVDF)                       |
| Support                   | Polypropylene (PP)  |
| Core/Cage/End Caps        | Polypropylene (PP)  |
| Cartridge End Cap Inserts | Polybutylene terephthalate (PBT)<br>(Cartridge exclusive)       |
| Cartridge End Cap O-rings | Silicone / EPDM / Fluoroelastomer /<br>PFA encapsulated O-rings |
| Capsule Housing           | Polypropylene (PP)  |
| Capsule Vent O-rings      | Silicone  |
| SP3 Capsule Port Insert   | 316L Stainless Steel  |
| SP3 Capsule Housing       | Polyetherimide (PEI)  |
| SP3 Capsule O-rings       | Silicone  |

### Maximum Differential Pressure

|                           |  |
|---------------------------|--|
| A - Standard Cartridge/   | Forward: 0.69 MPa @ 25 °C, 0.40 MPa @ 60 °C, 0.24 MPa @ 80 °C  |
| H - High Area Cartridge 1 | Reverse: 0.30 MPa @ 25 °C, 0.10 MPa @ 80 °C  |
| L - High Area Cartridge 2 | Forward: 0.55 MPa @ 25 °C, 0.40 MPa @ 60 °C, 0.24 MPa @ 80 °C<br>Reverse: 0.30 MPa @ 25 °C, 0.10 MPa @ 80 °C |
| Capsule                   | Forward: 0.55 MPa @ 25 °C, 0.1 MPa @ 80 °C<br>Reverse: 0.21 MPa @ 25 °C                                      |

### Integrity Test Standards

|  |   |
|--|---|
| Standard - 10inch<br>(0.55m <sup>2</sup> ) | Bubble Point @20 °C ≥ 0.18 MPa, air, wetted with water<br>Air Diffusion @20 °C ≤ 15 ml/min @0.15 MPa, wetted with water |
|--|---|

## Sterilization

|  |   |
|--|---|
| A - Standard Cartridge/<br>H - High Area Cartridge 1 | Can be steam sterilized for 30 minutes at 135 °C with 50 cycles (< 30 kPa)<br>Can be autoclaved 50 cycles for 30 minutes at 130°C                                   |
| L - High Area Cartridge 2                            | Can be steam sterilized for 30 minutes at 135 °C with 30 cycles (< 30 kPa)<br>Can be autoclaved 30 cycles for 30 minutes at 130°C                                   |
| Capsule  | Autoclavable capsules only : Can be autoclaved 25 cycles for 30 minutes at 130°C, (Can not be steam sterilized in-line)   |
|  | Gamma compatible capsules: Can be sterilized by gamma irradiation at 25-45 kGy or can be autoclaved 5 cycles for 60 minutes at 126 °C. (Can not be steamed in-line) |
|  | Sterile capsule: Can be sterilized by gamma irradiation at 25-45 kGy  |
|  | Cleansteam bag sterile package: Pre-sterilized with autoclave for 30 minutes at 121°C   |

Notes: Gamma sterilized products cannot be re-sterilized with gamma irradiation or steam sterilization

## Flow Rates

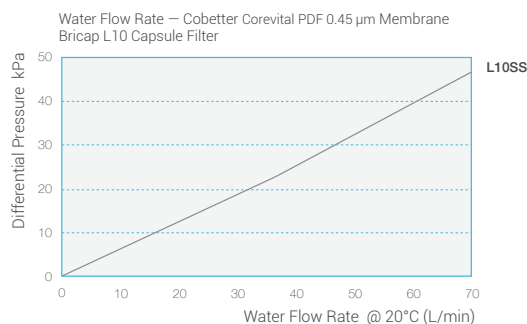
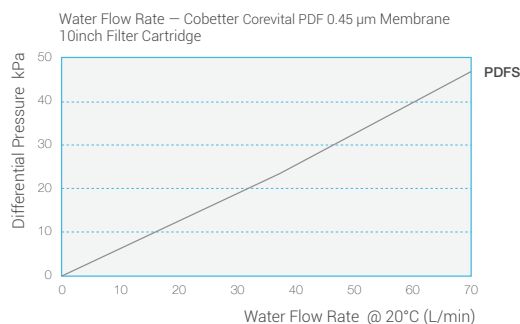

## Regulatory Compliance

- Effluent meets the USP<788> requirement of particulate matter in large volume injection.
- Component materials meet the criteria for a "Non-fiber-releasing filter" as defined in 21 CFR 210.3(b)(6).
- Retention of  $10^7$  cfu/cm<sup>2</sup> *Serratia marcescens* (ATCC 14756) according to ASTM F838
- Aqueous extraction from a cartridge contains less than 0.25EU/ml as determined by Limulus Amebocyte Lysate (LAL), meeting requirements of USP<85>.
- Components meet the requirement of USP <87> In Vitro Biological Reactivity Test.
- Components meet the criteria of the USP <88> Biological Reactivity Test for Class V-121 °C plastics.
- Components meet the FDA indirect Food Additive requirements cited in 21 CFR 177-182.
- Based on the current information from our suppliers, all components used in the manufacture of this product are animal-free.

Notes: Contact Cobetter for more specification details.

## Prefiltration and Bioburden Reduction Series

# Corevital PNDS Filter High Throughput and Low Protein Adsorption



### Features

- Double-layer design
- High throughput
- Low protein adsorption
- Reliable retention of bacteria and particles

### Typical Applications

- Buffer filtration
- Bioburden reduction
- Pre-column/ultra-filtration protection
- Protective filtration before sterile filtration

### Quality Control

- 100% integrity testing in manufacturing
- Each filter is fully traceable with unique serial number
- ISO 9001:2015 manufacturing facility

### Removal Rating and Effective Filtration Area

|                                 | PNDS(0.45 µm)       |
|---------------------------------|---------------------|
| A - Standard Cartridge (10")    | 0.55 m <sup>2</sup> |
| H - High Area Cartridge 1 (10") | 0.8 m <sup>2</sup>  |
| L - High Area Cartridge 2 (10") | 1.04 m <sup>2</sup> |

### Materials of Construction

|                           |   |
|---------------------------|---|
| Membrane                  | Hydrphilic polyvinylidene fluoride(PVDF)                        |
| Support                   | Polypropylene (PP)  |
| Core/Cage/End Caps        | Polypropylene (PP)  |
| Cartridge End Cap Inserts | Polybutylene terephthalate (PBT)<br>(Cartridge exclusive)       |
| Cartridge End Cap O-rings | Silicone / EPDM / Fluoroelastomer /<br>PFA encapsulated O-rings |
| Capsule Housing           | Polypropylene (PP)  |
| Capsule Vent O-rings      | Silicone  |
| SP3 Capsule Port Insert   | 316L Stainless Steel  |
| SP3 Capsule Housing       | Polyetherimide (PEI)  |
| SP3 Capsule O-rings       | Silicone  |

### Maximum Differential Pressure

|  |  |
|--|--|
| A - Standard Cartridge/<br>H - High Area Cartridge 1 | Forward: 0.69 MPa @ 25 °C, 0.40 MPa @ 60 °C, 0.24 MPa @ 80 °C<br>Reverse: 0.30 MPa @ 25 °C, 0.10 MPa @ 80 °C |
| L - High Area Cartridge 2                            | Forward: 0.55 MPa @ 25 °C, 0.40 MPa @ 60 °C, 0.24 MPa @ 80 °C<br>Reverse: 0.30 MPa @ 25 °C, 0.10 MPa @ 80 °C |
| Capsule  | Forward: 0.55 MPa @ 25 °C, 0.1 MPa @ 80 °C<br>Reverse: 0.21 MPa @ 25 °C                                      |

### Integrity Test Standards

|  |  |
|--|--|
| Standard - 10inch<br>(0.55m <sup>2</sup> ) | Bubble Point @20 °C ≥ 0.12 MPa, air, wetted with water |
|--|--|

## Sterilization

|  |   |
|--|---|
| A - Standard Cartridge/<br>H - High Area Cartridge 1 | Can be steam sterilized for 30 minutes at 135 °C with 50 cycles (< 30 kPa)<br>Can be autoclaved 50 cycles for 30 minutes at 130°C                                   |
| L - High Area Cartridge 2                            | Can be steam sterilized for 30 minutes at 135 °C with 30 cycles (< 30 kPa)<br>Can be autoclaved 30 cycles for 30 minutes at 130°C                                   |
| Capsule  | Autoclavable capsules only : Can be autoclaved 25 cycles for 30 minutes at 130°C, (Can not be steam sterilized in-line)   |
|  | Gamma compatible capsules: Can be sterilized by gamma irradiation at 25-45 kGy or can be autoclaved 5 cycles for 60 minutes at 126 °C. (Can not be steamed in-line) |
|  | Sterile capsule: Can be sterilized by gamma irradiation at 25-45 kGy  |
|  | Cleansteam bag sterile package: Pre-sterilized with autoclave for 30 minutes at 121°C   |

Notes: Gamma sterilized products cannot be re-sterilized with gamma irradiation or steam sterilization

## Flow Rates

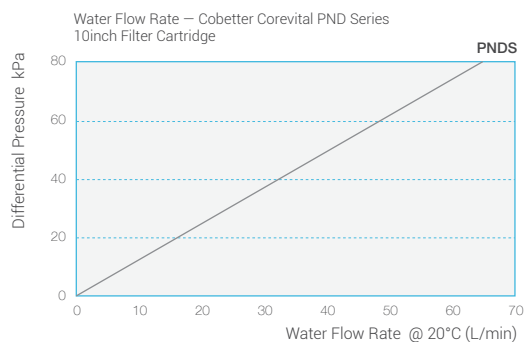

## Regulatory Compliance

- Effluent meets the USP<788> requirement of particulate matter in large volume injection.
- Component materials meet the criteria for a "Non-fiber-releasing filter" as defined in 21 CFR 210.3(b)(6).
- Retention of  $10^7$  cfu/cm<sup>2</sup> *Serratia marcescens* (ATCC 14756) according to ASTM F838
- Aqueous extraction from a cartridge contains less than 0.25EU/ml as determined by Limulus Amebocyte Lysate (LAL), meeting requirements of USP<85>.
- Components meet the requirement of USP <87> In Vitro Biological Reactivity Test.
- Components meet the criteria of the USP <88> Biological Reactivity Test for Class V-121 °C plastics.
- Components meet the FDA indirect Food Additive requirements cited in 21 CFR 177-182.
- Based on the current information from our suppliers, all components used in the manufacture of this product are animal-free.

Notes: Contact Cobetter for more specification details.

## Corevital PMDS/PDFS/PNDS Filter

### Ordering Information

#### Filter Cartridge



Cartridge Format

- A** Standard Cartridge
- H** H - High Area Cartridge(0.69-0.8m<sup>2</sup>)
- L** L - High Area Cartridge(1.0-1.2m<sup>2</sup>)



Membrane Type

- PMDS** PMD 1.0/0.45 µm
- PDFS** PDF 0.45 µm
- PNDS** PND 0.8/0.45 µm



Length

- 02** 2.5 inch
- 05** 5 inch
- 10** 10 inch
- 20** 20 inch
- 30** 30 inch
- 40** 40 inch



Code

- 0** DOE
- 2** 226 / Flat
- 7** 226 / Fin
- 3** 222 / Flat
- 8** 222 / Fin
- 6** 222 / 3-Flange bayonet / Fin



O-ring Material

- S** Silicone
- E** EPDM
- V** Fluoroelastomer
- P** FEP/PFA encapsulated O-rings



Pharmaceutical Grade

#### Bricap C Series Capsule Filter



Housing Type

- Blank** Standard
- K** Transparent



Capsule Format

- C01** Bricap C01
- C02** Bricap C02
- C03** Bricap C03



Inlet/Outlet

- T** 19 mm (3/4") Sanitary Flange
- K** 14 mm (9/16") Sanitary Flange
- F** 31 mm (1 1/4") Sanitary Flange
- V** 14 mm (9/16") Hose Barb
- H** 13 mm (1/2") Hose Barb
- Y** 9.6 mm (3/8") Hose Barb
- L** 3.2 mm (1/8") Hose Barb
- B** 6-13 mm (1/4"-1/2") Stepped Hose Barb (No Filling Bell)
- A** 6-13 mm (1/4"-1/2") Stepped Hose Barb with Filling Bell (Outlet only)

#### Bricap D Series Capsule Filter



Capsule Format

- D01** Bricap D01



Inlet/Outlet

- B** 6-13 mm (1/4"-1/2") Stepped Hose Barb (No Filling Bell)
- A** 6-13 mm (1/4"-1/2") Stepped Hose Barb with Filling Bell (Outlet only)

#### Bricap L Series Capsule Filter



Housing Type

- Blank** Standard
- K** Transparent



Capsule Format

- L02** Bricap L02
- L03** Bricap L03
- L05** Bricap L05
- L10** Bricap L10
- L20** Bricap L20
- L30** Bricap L30



Inlet/Outlet

- S** 38 mm (1 1/2") Sanitary Flange
- T** 19 mm (3/4") Sanitary Flange
- K** 14 mm (9/16") Sanitary Flange
- D** 25 mm (1") Hose Barb
- M** 19 mm (3/4") Hose Barb
- X** 16 mm (5/8") Hose Barb
- V** 14 mm (9/16") Hose Barb
- H** 13 mm (1/2") Hose Barb
- Y** 9.6 mm (3/8") Hose Barb

#### Bricap T Series Capsule Filter



Capsule Format

- T10** Bricap T10
- T20** Bricap T20
- T30** Bricap T30



Inlet/Outlet

- SS** 38 mm (1 1/2") Sanitary Flange Inlet & Outlet
- SM** 38 mm (1 1/2") Sanitary Flange Inlet & 19 mm (3/4") Hose Barb Outlet



Gauge Port Type

- S** 38 mm (1 1/2") Sanitary Flange
- T** 19 mm (3/4") Sanitary Flange
- N** Without Gauge Port

|   |   |   |                      |
|---|---|---|----------------------|
|   |   |   |                      |
| Membrane Type   | Sterilization   | Quantity/Package  | Pharmaceutical Grade |
| <ul style="list-style-type: none"> <li><b>PMDS</b> PMD 1.0/0.45 µm</li> <li><b>PDFS</b> PDF 0.45 µm</li> <li><b>PNDS</b> PND 0.8/0.45 µm</li> </ul> | <ul style="list-style-type: none"> <li><b>A</b> Autoclavable</li> <li><b>G</b> Gamma Compatible</li> <li><b>S</b> Sterile</li> <li><b>C</b> Cleansteam Bag Sterile Package</li> </ul> | <ul style="list-style-type: none"> <li><b>1</b> 1 /pkg</li> </ul> | Pharmaceutical Grade |

### Bricap HL Series Capsule Filter



Capsule Format

- HL02** Bricap HL02
- HL03** Bricap HL03
- HL05** Bricap HL05
- HL10** Bricap HL10
- HL20** Bricap HL20
- HL30** Bricap HL30



Inlet/Outlet

- S** 38 mm (1 1/2") Sanitary Flange
- T** 19 mm (3/4") Sanitary Flange
- V** 14 mm (9/16") Hose Barb
- D** 25 mm (1") Hose Barb
- H** 13 mm (1/2") Hose Barb
- Y** 9.6 mm (3/8") Hose Barb



Membrane Type

- HPMDS** HPMD 1.0/0.45 µm
- LPMDS** LPMD 1.0/0.45 µm
- HPDFS** HPDF 0.45 µm
- LPDFS** LPDF 0.45 µm
- HPNDS** HPND 0.8/0.45 µm
- LPNDS** LPND 0.8/0.45 µm



Sterilization

- A** Autoclavable
- G** Gamma Compatible
- S** Sterile
- C** Cleansteam Bag Sterile Package



Quantity/Package

- 1** 1 /pkg



Pharmaceutical Grade

### Bricap HT Series Capsule Filter



Capsule Format

- HT02** Bricap HT02
- HT03** Bricap HT03
- HT05** Bricap HT05
- HT10** Bricap HT10
- HT20** Bricap HT20
- HT30** Bricap HT30



Inlet/Outlet

- SS** 38 mm (1 1/2") Sanitary Flange
- SM** 38 mm (1 1/2") Sanitary Flange Inlet and 19 mm (3/4") Hose Barb Outlet



Gauge Port Type

- S** 38 mm (1 1/2") Sanitary Flange
- T** 19 mm (3/4") Sanitary Flange
- N** None

### Brisip SP3 Series Capsule Filter



Capsule Format

- SP3** Brisip SP3



Inlet/Outlet

- S** 38 mm (1 1/2") Sanitary Flange



Membrane Type

- PMDS** PMD 1.0/0.45 µm
- PDFS** PDF 0.45 µm
- PNDS** PND 0.8/0.45 µm



Vent and Drain Valves

- P** Both using 6 mm hose barb
- X** Vent valve using quick coupling (compatible with Stäubli connector), and drain valve using 6 mm hose barb
- T** Both using quick coupling (compatible with Stäubli connector)
- V** Both using 13 mm (1/2") sanitary flange



Quantity/Package

- 1** 1 /pkg



Pharmaceutical Grade

### BriScale A50 Liquid Disc Filter



Disc Filter Format

- A50** BriScale A50



Inlet/Outlet

- BB** 6-13 mm (1/4"-1/2") Stepped Hose Barb Inlet and Outlet (No Filling Bell)
- BA** 6-13 mm (1/4"-1/2") Stepped Hose Barb Inlet and Outlet (Outlet with Filling Bell)



Membrane Type

- PMDS** PMD 1.0/0.45 µm
- PDFS** PDF 0.45 µm
- PNDS** PND 0.8/0.45 µm



Sterilization

- A** Autoclavable
- G** Gamma Compatible
- S** Sterile



Quantity/Package

- 1** 1 /pkg



Pharmaceutical Grade

### Bricap SFU Series Syringe Filter (No Vent)



Syringe Filter Format

- U13** Bricap SFU13
- U25** Bricap SFU25
- U33** Bricap SFU33



Inlet/Outlet

- CP** Female luer lock inlet and male luer lock outlet

### Bricap SFV Series Syringe Filter (With Luer Vent)



Syringe Filter Format

- V25** Bricap SFV25



Inlet/Outlet

- CP** Female luer lock inlet and male luer lock outlet

## Mycoplasma Removal Filter Series

# Corevital MMDA Filter

## Hydrophilic Filter with High Mycoplasma Retention Rate



### Features

Low adsorption

### Typical Applications

Mycoplasma removal application  
 Mycoplasma removal from buffer  
 Intermediate product filtration  
 Stock solution filtration  
 Terminal product filtration

### Quality Control

100% integrity testing in manufacturing  
 Each filter is fully traceable with unique serial number  
 ISO 9001:2015 manufacturing facility

### Removal Rating and Effective Filtration Area

|                              | MMDA(0.1/0.1µm)     |
|------------------------------|---------------------|
| A - Standard Cartridge (10") | 0.55 m <sup>2</sup> |

### Materials of Construction

|                           |   |
|---------------------------|---|
| Membrane                  | Hydrophilic polyvinylidene fluoride(PVDF)                       |
| Support                   | Polypropylene (PP)  |
| Core/Cage/End Caps        | Polypropylene (PP)  |
| Cartridge End Cap Inserts | Polybutylene terephthalate (PBT)<br>(Cartridge exclusive)       |
| Cartridge End Cap O-rings | Silicone / EPDM / Fluoroelastomer /<br>PFA encapsulated O-rings |
| Capsule Housing           | Polypropylene (PP)  |
| Capsule Vent O-rings      | Silicone  |

### Maximum Differential Pressure

|                        |   |
|------------------------|---|
| A - Standard Cartridge | Forward: 0.69 MPa @ 25 °C, 0.40 MPa @ 60 °C, 0.24 MPa @ 80 °C |
|                        | Reverse: 0.30 MPa @ 25 °C, 0.10 MPa @ 80 °C                   |
| Capsule                | Forward: 0.55 MPa @ 25 °C, 0.1 MPa @ 80 °C                    |
|                        | Reverse: 0.21 MPa @ 25 °C                                     |

### Integrity Test Standards

|  |  |
|--|--|
| Standard - 10inch<br>(0.55m <sup>2</sup> ) | Bubble Point @20 °C ≥ 0.48 MPa, air, wetted with water           |
|  | Air Diffusion @ 20 °C ≤ 20 ml/min @ 0.386 MPa, wetted with water |

## Sterilization

|                        |   |
|------------------------|---|
| A - Standard Cartridge | Can be steam sterilized for 30 minutes at 135 °C with 50 cycles (< 30 kPa)<br>Can be autoclaved 50 cycles for 30 minutes at 130°C   |
| Capsule                | Autoclavable capsules only : Can be autoclaved 25 cycles for 30 minutes at 130°C, (Can not be steam sterilized in-line)<br>Gamma compatible capsules: Can be sterilized by gamma irradiation at 25-45 kGy or can be autoclaved 5 cycles for 60 minutes at 126 °C. (Can not be steamed in-line)<br>Sterile capsule: Can be sterilized by gamma irradiation at 25-45 kGy<br>Cleansteam bag sterile package: Pre-sterilized with autoclave for 30 minutes at 121°C |

Notes: Gamma sterilized products cannot be re-sterilized with gamma irradiation or steam sterilization

## Flow Rates

Water Flow Rate — Cobetter Corevital MMD 0.1/0.1 µm Membrane  
Bricap C03 Capsule Filter

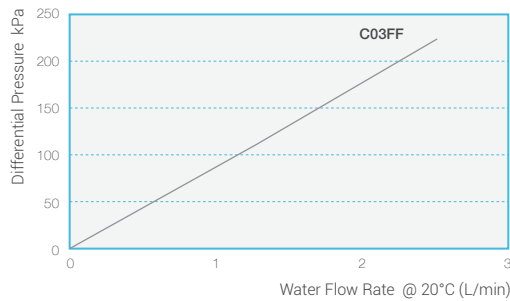

Water Flow Rate — Cobetter Corevital MMD 0.1/0.1 µm Membrane  
Bricap L10 Capsule Filter

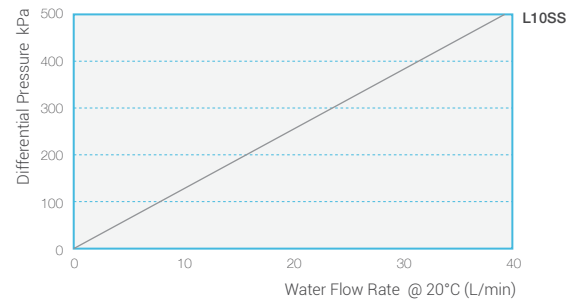

Water Flow Rate — Cobetter Corevital MMD 0.1 µm Membrane  
10inch Filter Cartridge

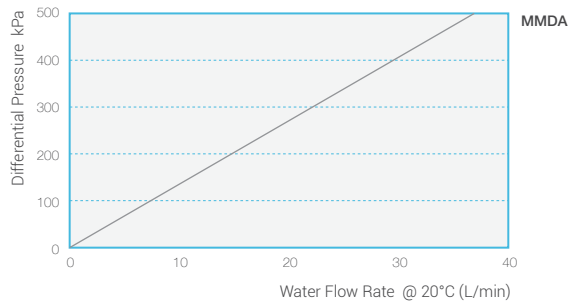

## Regulatory Compliance

- Effluent meets the USP<788> requirement of particulate matter in large volume injection.
- Component materials meet the criteria for a "Non-fiber-releasing filter" as defined in 21 CFR 210.3(b)(6).
- Retention of  $10^7$  cfu/cm<sup>2</sup> *Brevundimonas diminuta* (ATCC 19146) according to ASTM F838
- Typical Log Reduction Value (LRV) >7 of *Acholeplasma laidlawii* (ATCC 23206) according to ASTM F838
- Aqueous extraction from a cartridge contains less than 0.25EU/ml as determined by Limulus Amebocyte Lysate (LAL), meeting requirements of USP<85>.
- Components meet the requirement of USP <87> In Vitro Biological Reactivity Test.
- Components meet the criteria of the USP <88> Biological Reactivity Test for Class V-121 °C plastics.
- Components meet the FDA indirect Food Additive requirements cited in 21 CFR 177-182.
- Based on the current information from our suppliers, all components used in the manufacture of this product are animal-free.

Notes: Contact Cobetter for more specification details.



## Corevital MMDA 0.1µm Filter

### Ordering Information

#### Filter Cartridge



Cartridge Format

**A** Standard Cartridge



Membrane Type

**MMDA** MMD 0.1/0.1µm



Length

**02** 2.5 inch  
**05** 5 inch  
**10** 10 inch  
**20** 20 inch  
**30** 30 inch  
**40** 40 inch



Code

**0** DOE  
**2** 226 / Flat  
**7** 226 / Fin  
**3** 222 / Flat  
**8** 222 / Fin  
**6** 222 / 3-Flange bayonet / Fin



O-ring Material

**S** Silicone  
**E** EPDM  
**V** Fluoroelastomer  
**P** FEP/PFA encapsulated O-rings



Pharmaceutical Grade

#### Bricap C Series Capsule Filter



Housing Type

**Blank** Standard  
**K** Transparent



Capsule Format

**C01** BricapC01  
**C02** BricapC02  
**C03** Bricap C03



Inlet/Outlet

**T** 19 mm(3/4") Sanitary Flange  
**K** 14 mm (9/16") Sanitary Flange  
**F** 31 mm (1 1/4") Sanitary Flange  
**V** 14 mm (9/16") Hose Barb  
**H** 13 mm (1/2") Hose Barb  
**Y** 9.6 mm (3/8") Hose Barb  
**L** 3.2 mm (1/8") Hose Barb  
**B** 6-13 mm (1/4"-1/2") Stepped Hose Barb (No Filling Bell)  
**A** 6-13 mm (1/4"-1/2") Stepped Hose Barb with Filling Bell (Outlet only)

#### Bricap D Series Capsule Filter



Capsule Format

**D01** BricapD01



Inlet/Outlet

**B** 6-13 mm (1/4"-1/2") Stepped Hose Barb (No Filling Bell)  
**A** 6-13 mm (1/4"-1/2") Stepped Hose Barb with Filling Bell (Outlet only)



Membrane Type

**MMDA** MMD 0.1/0.1µm



Sterilization

**A** Autoclavable  
**G** Gamma Compatible  
**S** Sterile  
**C** Cleansteam Bag Sterile Package





Quantity/Package

**1** 1 /pkg









Pharmaceutical Grade

### Bricap L Series Capsule Filter

|  |   |   |
|--|---|---|
|  |  |  |
| Housing Type   | Capsule Format  | Inlet/Outlet  |
| <b>Blank</b> Standard  | <b>L02</b> Bricap L02   | <b>S</b> 38 mm (1 1/2") Sanitary Flange   |
| <b>K</b> Transparent   | <b>L03</b> Bricap L03   | <b>T</b> 19 mm (3/4") Sanitary Flange   |
|  | <b>L05</b> Bricap L05   | <b>K</b> 14 mm (9/16") Sanitary Flange  |
|  | <b>L10</b> Bricap L10   | <b>D</b> 25 mm (1") Hose Barb   |
|  | <b>L20</b> Bricap L20   | <b>M</b> 19 mm (3/4") Hose Barb   |
|  | <b>L30</b> Bricap L30   | <b>X</b> 16 mm (5/8") Hose Barb   |
|  |   | <b>V</b> 14 mm (9/16") Hose Barb  |
|  |   | <b>H</b> 13 mm (1/2") Hose Barb   |
|  |   | <b>Y</b> 9.6 mm (3/8") Hose Barb  |

### Bricap T Series Capsule Filter

|  |   |   |
|--|---|---|
|  |  |  |
| Capsule Format   | Inlet/Outlet  | Gauge Port Type   |
| <b>T10</b> Bricap T10  | <b>SS</b> 38 mm (1 1/2") Sanitary Flange Inlet & Outlet                           | <b>S</b> 38 mm (1 1/2") Sanitary Flange   |
| <b>T20</b> Bricap T20  | <b>SM</b> 38 mm (1 1/2") Sanitary Flange Inlet & 19 mm (3/4") Hose Barb Outlet    | <b>T</b> 19 mm (3/4") Sanitary Flange   |
| <b>T30</b> Bricap T30  |   | <b>N</b> Without Gauge Port   |

|   |   |   |   |
|---|---|---|---|
|  |                                |  |  |
| Membrane Type   | Sterilization   | Quantity/Package  | Pharmaceutical Grade  |
| <b>MMDA</b> MMD 0.1/0.1 μm  | <b>A</b> Autoclavable<br><b>G</b> Gamma Compatible<br><b>S</b> Sterile<br><b>C</b> Cleansteam Bag Sterile Package | <b>1</b> 1 /pkg   | Pharmaceutical Grade  |

## Sterilizing-Grade Filter Series

# Safesatable SHBB Filter

## Hydrophilic Sterilizing-Grade Filter



### Features

Great chemical compatibility  
Hydrophilic PTFE membrane

### Typical Applications

Sterile Filtration of organic compounds  
Filtration of disinfectant  
Filtration of strong acid and alkali  
High temperature filtration

### Quality Control

100% integrity testing in manufacturing  
Each filter is fully traceable with unique serial number  
ISO 9001:2015 manufacturing facility

### Removal Rating and Effective Filtration Area

|                              | SHBB(0.2µm)         |
|------------------------------|---------------------|
| A - Standard Cartridge (10") | 0.56 m <sup>2</sup> |

### Materials of Construction

|                           |   |
|---------------------------|---|
| Membrane                  | Hydrophilic Polytetrafluoroethylene (PTFE)                      |
| Support                   | Polypropylene (PP)  |
| Core/Cage/End Caps        | Polypropylene (PP)  |
| Cartridge End Cap Inserts | Polybutylene terephthalate (PBT)<br>(Cartridge exclusive)       |
| Cartridge End Cap O-rings | Silicone / EPDM / Fluoroelastomer /<br>PFA encapsulated O-rings |
| Capsule Housing           | Polypropylene (PP)  |
| Capsule Vent O-rings      | Silicone  |

### Maximum Differential Pressure

|                        |   |
|------------------------|---|
| A - Standard Cartridge | Forward: 0.69 MPa @ 25 °C, 0.40 MPa @ 60 °C, 0.24 MPa @ 80 °C |
|                        | Reverse: 0.30 MPa @ 25 °C, 0.10 MPa @ 80 °C                   |
| Capsule                | Forward: 0.55 MPa @ 25 °C, 0.1 MPa @ 80 °C                    |
|                        | Reverse: 0.21 MPa @ 25 °C                                     |

### Integrity Test Standards

|  |  |
|--|--|
| Standard - 10inch<br>(0.56m <sup>2</sup> ) | Bubble Point @20 °C ≥ 0.33 MPa, air, wetted with water |
|--|--|

## Sterilization

|                        |  |
|------------------------|--|
| A - Standard Cartridge | Can be steam sterilized for 30 minutes at 135 °C with 35 cycles (< 30 kPa)<br>Can be autoclaved 35 cycles for 30 minutes at 130°C  |
| Capsule                | Autoclavable capsules only : Can be autoclaved 25 cycles for 30 minutes at 130°C, (Can not be steam sterilized in-line)<br>Cleansteam bag sterile package: Pre-sterilized with autoclave for 30 minutes at 121°C |

Notes: Gamma sterilized products cannot be re-sterilized with gamma irradiation or steam sterilization

## Flow Rates

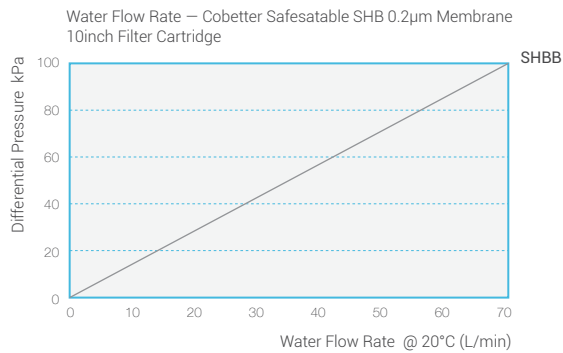

## Regulatory Compliance







- Effluent meets the USP<788> requirement of particulate matter in large volume injection.
- Component materials meet the criteria for a "Non-fiber-releasing filter" as defined in 21 CFR 210.3(b)(6).
- Retention of  $10^7$  cfu/cm<sup>2</sup> *Brevundimonas diminuta* (ATCC 19146) according to ASTM F838
- Aqueous extraction from a cartridge contains less than 0.25EU/ml as determined by Limulus Amebocyte Lysate (LAL), meeting requirements of USP<85>.
- Components meet the requirement of USP <87> In Vitro Biological Reactivity Test.
- Components meet the criteria of the USP <88> Biological Reactivity Test for Class V-121 °C plastics.
- Components meet the FDA indirect Food Additive requirements cited in 21 CFR177-182.
- Based on the current information from our suppliers, all components used in the manufacture of this product are animal-free.

Notes: Contact Cobetter for more specification details.







## Safesatable SHBB Filter

### Ordering Information



#### Filter Cartridge

|  |   |  |   |   |   |
|--|---|--|---|---|---|
|  |  |   |    |                      |  |
| Cartridge Format   | Membrane Type   | Length   | Code  | O-ring Material   | Pharmaceutical Grade  |
| <b>A</b> Standard Cartridge  | <b>SHBB</b> SHB 0.2 µm  | <b>02</b> 2.5 inch<br><b>05</b> 5 inch<br><b>10</b> 10 inch<br><b>20</b> 20 inch<br><b>30</b> 30 inch<br><b>40</b> 40 inch | <b>0</b> DOE<br><b>2</b> 226 / Flat<br><b>7</b> 226 / Fin<br><b>3</b> 222 / Flat<br><b>8</b> 222 / Fin<br><b>6</b> 222 / 3-Flange bayonet / Fin | <b>S</b> Silicone<br><b>E</b> EPDM<br><b>V</b> Fluoroelastomer<br><b>P</b> FEP/PFA encapsulated O-rings |   |



#### Bricap C Series Capsule Filter

|  |   |   |   |   |   |   |
|--|---|---|---|---|---|---|
|  |  |    |  |  |  |  |
| Housing Type   | Capsule Format  | Inlet/Outlet  | Membrane Type   | Sterilization   | Quantity/Package  | Pharmaceutical Grade  |
| <b>Blank</b> Standard<br><b>K</b> Transparent                                    | <b>C01</b> Bricap C01<br><b>C02</b> Bricap C02<br><b>C03</b> Bricap C03           | <b>T</b> 19 mm (3/4") Sanitary Flange<br><b>K</b> 14 mm (9/16") Sanitary Flange<br><b>F</b> 31 mm (1 1/4") Sanitary Flange<br><b>V</b> 14 mm (9/16") Hose Barb<br><b>H</b> 13 mm (1/2") Hose Barb<br><b>Y</b> 9.6 mm (3/8") Hose Barb<br><b>L</b> 3.2 mm (1/8") Hose Barb<br><b>B</b> 6-13 mm (1/4"-1/2") Stepped Hose Barb (No Filling Bell)<br><b>A</b> 6-13 mm (1/4"-1/2") Stepped Hose Barb with Filling Bell (Outlet only) | <b>SHBB</b> SHB 0.2 µm  | <b>A</b> Autoclavable<br><b>C</b> Sterile Package                                   | <b>1</b> 1 /pkg   |   |

#### Bricap D Series Capsule Filter

|  |  |
|--|--|
|  |   |
| Capsule Format   | Inlet/Outlet   |
| <b>D01</b> Bricap D01  | <b>B</b> 6-13 mm (1/4"-1/2") Stepped Hose Barb (No Filling Bell)<br><b>A</b> 6-13 mm (1/4"-1/2") Stepped Hose Barb with Filling Bell (Outlet only) |

#### Bricap L Series Capsule Filter

|  |  |  |
|--|--|--|
|  |   |   |
| Housing Type   | Capsule Format   | Inlet/Outlet   |
| <b>Blank</b> Standard<br><b>K</b> Transparent                                      | <b>L02</b> Bricap L02<br><b>L03</b> Bricap L03<br><b>L05</b> Bricap L05<br><b>L10</b> Bricap L10<br><b>L20</b> Bricap L20<br><b>L30</b> Bricap L30 | <b>S</b> 38 mm (1 1/2") Sanitary Flange<br><b>T</b> 19 mm (3/4") Sanitary Flange<br><b>K</b> 14 mm (9/16") Sanitary Flange<br><b>D</b> 25 mm (1") Hose Barb<br><b>M</b> 19 mm (3/4") Hose Barb<br><b>X</b> 16 mm (5/8") Hose Barb<br><b>V</b> 14 mm (9/16") Hose Barb<br><b>H</b> 13 mm (1/2") Hose Barb<br><b>Y</b> 9.6 mm (3/8") Hose Barb |

### Bricap T Series Capsule Filter



Capsule Format

- T10** Bricap T10
- T20** Bricap T20
- T30** Bricap T30



Inlet/Outlet

- SS** 38 mm (1 1/2") Sanitary Flange Inlet & Outlet
- SM** 38 mm (1 1/2") Sanitary Flange Inlet & 19 mm (3/4") Hose Barb Outlet



Gauge Port Type

- S** 38 mm (1 1/2") Sanitary Flange
- T** 19 mm (3/4") Sanitary Flange
- N** Without Gauge Port

### BriScale A50 Liquid Disc Filter



Disc Filter Format

- A50** BriScale A50



Inlet/Outlet

- BB** 6-13 mm (1/4"-1/2") Stepped Hose Barb Inlet and Outlet (No Filling Bell)
- BA** 6-13 mm (1/4"-1/2") Stepped Hose Barb Inlet and Outlet (Outlet with Filling Bell)

### Bricap SFU Series Syringe Filter (No Vent)



Syringe Filter Format

- U13** Bricap SFU13
- U25** Bricap SFU25
- U33** Bricap SFU33



Inlet/Outlet

- CP** Female luer lock inlet and male luer lock outlet

### Bricap SFV Series Syringe Filter (With Luer Vent)



Syringe Filter Format

- V25** Bricap SFV25



Inlet/Outlet

- CP** Female luer lock inlet and male luer lock outlet

|  |   |  |   |
|--|---|--|---|
| <div style="border: 1px solid black; width: 80px; height: 20px; margin-bottom: 5px;"></div> <p>Membrane Type</p> <p><b>SHBB</b> SHB 0.2 µm</p> | <div style="border: 1px solid black; width: 30px; height: 20px; margin-bottom: 5px;"></div> <p>Sterilization</p> <p><b>A</b> Autoclavable</p> | <div style="border: 1px solid black; width: 30px; height: 20px; margin-bottom: 5px;"></div> <p>Quantity/Package</p> <p><b>1</b> 1 /pkg</p> | <div style="background-color: #0070c0; color: white; padding: 2px 5px; display: inline-block; font-weight: bold;">P</div> <p>Pharmaceutical Grade</p> |
|--|---|--|---|

## Gas Filtration Series

# Corevital APB Filter Gamma-Resistant Hydrophobic Filter



### Features

- High throughput, high retention rate
- Low differential pressure
- Reliable retention of bacteria and particles
- Gamma resistant

### Typical Applications

- Vent filter for fermentation, storage tanks
- Sterile filtration for compressed air, oxygen, nitrogen
- Single-use system application

### Quality Control

- 100% integrity testing in manufacturing
- Each filter is fully traceable with unique serial number
- ISO 9001:2015 manufacturing facility

### Removal Rating and Effective Filtration Area

|                              | APBB(0.2µm)         |
|------------------------------|---------------------|
| A - Standard Cartridge (10") | 0.75 m <sup>2</sup> |

### Materials of Construction

|                           |   |
|---------------------------|---|
| Membrane                  | Hydrophobic polyvinylidene fluoride (PVDF)                      |
| Support                   | Polypropylene (PP)  |
| Core/Cage/End Caps        | Polypropylene (PP)  |
| Cartridge End Cap Inserts | Polybutylene terephthalate (PBT)<br>(Cartridge exclusive)       |
| Cartridge End Cap O-rings | Silicone / EPDM / Fluoroelastomer /<br>PFA encapsulated O-rings |
| Capsule Housing           | Polypropylene (PP)  |
| Capsule Vent O-rings      | Silicone  |

### Maximum Differential Pressure

|                        |   |
|------------------------|---|
| A - Standard Cartridge | Forward: 0.69 MPa @ 25 °C, 0.40 MPa @ 60 °C, 0.24 MPa @ 80 °C |
|                        | Reverse: 0.30 MPa @ 25 °C, 0.10 MPa @ 80 °C                   |
| Capsule                | Forward: 0.55 MPa @ 25 °C, 0.1 MPa @ 80 °C                    |
|                        | Reverse: 0.21 MPa @ 25 °C                                     |

### Integrity Test Standards

|  |   |
|--|---|
| Standard - 10inch<br>(0.75m <sup>2</sup> ) | Bubble Point @ 20 °C: ≥ 0.11 MPa, 60% IPA 40%, air, wetted with water |
|  | Water Intrusion @ 20 °C: ≤ 0.75 ml/min @ 0.18 MPa                     |

### Sterilization

|                        |   |
|------------------------|---|
| A - Standard Cartridge | Can be steam sterilized for 30 minutes at 135 °C with 50 cycles (< 30 kPa)  |
|                        | Can be autoclaved 50 cycles for 30 minutes at 130°C   |
| Capsule                | Autoclavable capsules only : Can be autoclaved 25 cycles for 30 minutes at 130°C, (Can not be steam sterilized in-line)   |
|                        | Gamma compatible capsules: Can be sterilized by gamma irradiation at 25-45 kGy or can be autoclaved 5 cycles for 60 minutes at 126 °C. (Can not be steamed in-line) |
|                        | Sterile capsule: Can be sterilized by gamma irradiation at 25-45 kGy  |
|                        | Cleansteam bag sterile package: Pre-sterilized with autoclave for 30 minutes at 121 °C  |

Notes: Gamma sterilized products cannot be re-sterilized with gamma irradiation or steam sterilization

## Flow Rates

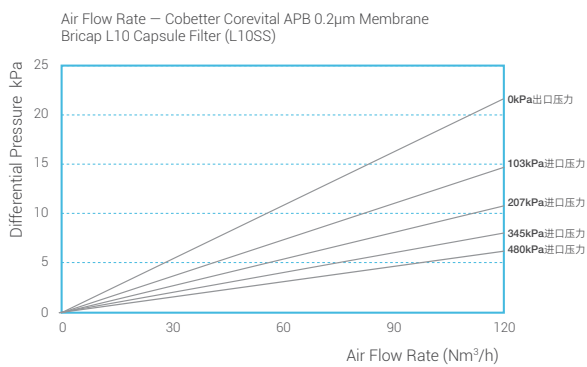
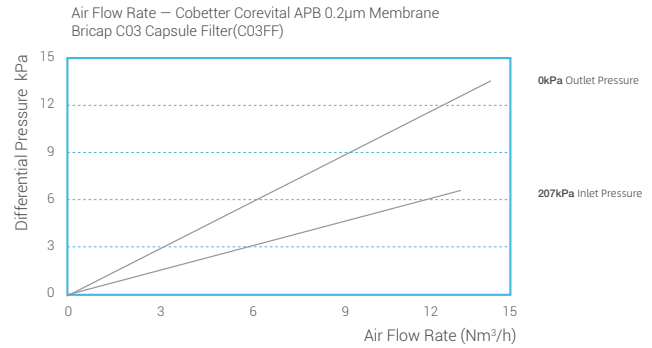
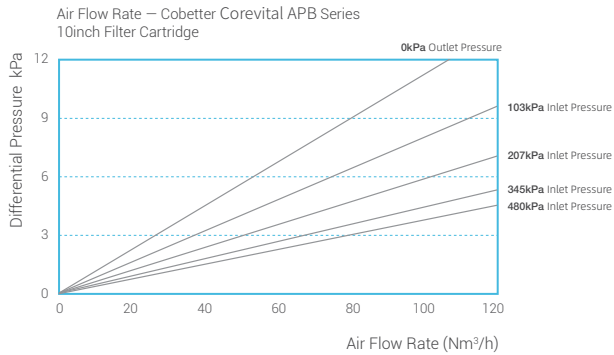

## Regulatory Compliance

- Effluent meets the USP<788> requirement of particulate matter in large volume injection.
- Component materials meet the criteria for a "Non-fiber-releasing filter" as defined in 21 CFR 210.3(b)(6).
- Retention of  $10^7$  cfu/cm<sup>2</sup> *Brevundimonas diminuta* (ATCC 19146) according to ASTM F838
- Typical Log Reduction Value (LRV) >7 using  $>10^8$  pfu Bacteriophage Phi-X174 (ATCC 13706-B1)
- Aqueous extraction from a cartridge contains less than 0.25EU/ml as determined by Limulus Amebocyte Lysate (LAL), meeting requirements of USP<85>.
- Components meet the requirement of USP <87> In Vitro Biological Reactivity Test.
- Components meet the criteria of the USP <88> Biological Reactivity Test for Class V-121 °C plastics.
- Components meet the FDA indirect Food Additive requirements cited in 21 CFR 177-182.
- Based on the current information from our suppliers, all components used in the manufacture of this product are animal-free.







Notes: Contact Cobetter for more specification details.









## Corevital APBB Filter

### Ordering Information



#### Filter Cartridge

|  |   |  |   |   |   |
|--|---|--|---|---|---|
|  |  |   |    |                      |  |
| Cartridge Format   | Membrane Type   | Length   | Code  | O-ring Material   | Pharmaceutical Grade  |
| <b>A</b> Standard Cartridge  | <b>APBB</b> APB 0.2µm   | <b>02</b> 2.5 inch<br><b>05</b> 5 inch<br><b>10</b> 10 inch<br><b>20</b> 20 inch<br><b>30</b> 30 inch<br><b>40</b> 40 inch | <b>0</b> DOE<br><b>2</b> 226 / Flat<br><b>7</b> 226 / Fin<br><b>3</b> 222 / Flat<br><b>8</b> 222 / Fin<br><b>6</b> 222 / 3-Flange bayonet / Fin | <b>S</b> Silicone<br><b>E</b> EPDM<br><b>V</b> Fluoroelastomer<br><b>P</b> FEP/PFA encapsulated O-rings |   |



#### Bricap C Series Capsule Filter

|  |   |   |   |   |   |   |
|--|---|---|---|---|---|---|
|  |  |    |  |                                |  |  |
| Housing Type   | Capsule Format  | Inlet/Outlet  | Membrane Type   | Sterilization   | Quantity/Package  | Pharmaceutical Grade  |
| <b>Blank</b> Standard<br><b>K</b> Transparent                                    | <b>C01</b> Bricap C01<br><b>C02</b> Bricap C02<br><b>C03</b> Bricap C03           | <b>T</b> 19 mm (3/4") Sanitary Flange<br><b>K</b> 14 mm (9/16") Sanitary Flange<br><b>F</b> 31 mm (1 1/4") Sanitary Flange<br><b>V</b> 14 mm (9/16") Hose Barb<br><b>H</b> 13 mm (1/2") Hose Barb<br><b>Y</b> 9.6 mm (3/8") Hose Barb<br><b>L</b> 3.2 mm (1/8") Hose Barb<br><b>B</b> 6-13 mm (1/4"-1/2") Stepped Hose Barb (No Filling Bell)<br><b>A</b> 6-13 mm (1/4"-1/2") Stepped Hose Barb with Filling Bell (Outlet only) | <b>APBB</b> APB 0.2µm   | <b>A</b> Autoclavable<br><b>G</b> Gamma Compatible<br><b>S</b> Sterile<br><b>C</b> Cleansteam Bag Sterile Package | <b>1</b> 1 /pkg   |   |







#### Bricap D Series Capsule Filter

|  |  |
|--|--|
|  |   |
| Capsule Format   | Inlet/Outlet   |
| <b>D01</b> Bricap D01  | <b>B</b> 6-13 mm (1/4"-1/2") Stepped Hose Barb (No Filling Bell)<br><b>A</b> 6-13 mm (1/4"-1/2") Stepped Hose Barb with Filling Bell (Outlet only) |

#### Bricap L Series Capsule Filter

|  |  |  |
|--|--|--|
|  |   |   |
| Housing Type   | Capsule Format   | Inlet/Outlet   |
| <b>Blank</b> Standard<br><b>K</b> Transparent                                      | <b>L02</b> Bricap L02<br><b>L03</b> Bricap L03<br><b>L05</b> Bricap L05<br><b>L10</b> Bricap L10<br><b>L20</b> Bricap L20<br><b>L30</b> Bricap L30 | <b>S</b> 38 mm (1 1/2") Sanitary Flange<br><b>T</b> 19 mm (3/4") Sanitary Flange<br><b>K</b> 14 mm (9/16") Sanitary Flange<br><b>D</b> 25 mm (1") Hose Barb<br><b>M</b> 19 mm (3/4") Hose Barb<br><b>X</b> 16 mm (5/8") Hose Barb<br><b>V</b> 14 mm (9/16") Hose Barb<br><b>H</b> 13 mm (1/2") Hose Barb<br><b>Y</b> 9.6 mm (3/8") Hose Barb |

#### Bricap T Series Capsule Filter

|  |   |   |   |   |   |   |
|--|---|---|---|---|---|---|
|  |    |                              |  |  |  |  |
| Capsule Format   | Inlet/Outlet  | Gauge Port Type   | Membrane Type   | Sterilization   | Quantity/Package  | Pharmaceutical Grade  |
| <b>T10</b> Bricap T10<br><b>T20</b> Bricap T20<br><b>T30</b> Bricap T30            | <b>SS</b> 38 mm (1 1/2") Sanitary Flange Inlet & Outlet<br><b>SM</b> 38 mm (1 1/2") Sanitary Flange Inlet & 19 mm (3/4") Hose Barb Outlet | <b>S</b> 38 mm (1 1/2") Sanitary Flange<br><b>T</b> 19 mm (3/4") Sanitary Flange<br><b>N</b> Without Gauge Port | <b>APBB</b> APB 0.2µm   | <b>A</b> Autoclavable<br><b>G</b> Gamma Compatible<br><b>S</b> Sterile                | <b>1</b> 1 /pkg   |   |

## Gas Filtration Series

# Safesure AFBB Filter Hydrophobic Filter



### Features

PTFE is inherently hydrophobic and further processed for even more hydrophobic, maintaining sterilizing capacity in both unwet and wet condition  
 Oleo-phobic  
 High retention rates, low pressure differential  
 Use of heat resistant thickened PP as core, better heat resistance and pressure resistance  
 Heat resistance, can be steamed in line and autoclaved repeatedly

### Typical Applications

Vent filter for fermentation, storage tanks  
 Sterile filtration for compressed air, oxygen, nitrogen  
 Single-use system application

### Quality Control

100% integrity testing in manufacturing  
 Each filter is fully traceable with unique serial number  
 ISO 9001:2015 manufacturing facility

### Removal Rating and Effective Filtration Area

|                              | AFBB(0.2µm)         |
|------------------------------|---------------------|
| A - Standard Cartridge (10") | 0.80 m <sup>2</sup> |

### Materials of Construction

|                           |   |
|---------------------------|---|
| Membrane                  | Hydrophobic Polytetrafluoroethylene (PTFE)                            |
| Support                   | Polypropylene (PP)  |
| Core/Cage/End Caps        | Polypropylene (PP)  |
| Cartridge End Cap Inserts | 316L Stainless Steel/Polybutylene Terephthalate(PBT)(Cartridges Only) |
| Cartridge End Cap O-rings | Silicone/Viton/EPDM<br>PEP/PFA encapsulated O-ring                    |
| Capsule Housing           | Polypropylene (PP)  |
| Capsule Vent O-rings      | Silicone  |
| SP3 Capsule Port Insert   | 316L Stainless Steel  |
| SP3 Capsule Housing       | Polyetherimide (PEI)  |
| SP3 Capsule O-rings       | Silicone  |

### Maximum Differential Pressure

|                        |  |
|------------------------|--|
| A - Standard Cartridge | Forward: 0.69 MPa @ 25 °C, 0.40 MPa @ 60 °C, 0.24 MPa @ 80 °C<br>Reverse: 0.30 MPa @ 25 °C, 0.10 MPa @ 80 °C |
| Capsule                | Forward: 0.55 MPa @ 25 °C, 0.1 MPa @ 80 °C<br>Reverse: 0.21 MPa @ 25 °C                                      |

### Integrity Test Standards

|   |  |
|---|--|
| Standard - 10inch (0.80m <sup>2</sup> ) | Water Flow Test @ 20 °C: ≤0.84 ml/min @ 0.25 MPa |
|---|--|

### Sterilization

|                        |  |
|------------------------|--|
| A - Standard Cartridge | Can be steam sterilized for 30 minutes at 145 °C in forward direction (<30kPa) with 100 cycles plus in reverse direction (<10kPa), 150 cycles in total.<br>Can be autoclaved 200 cycles for 30 min at 130 °C |
| Capsule                | Autoclavable Capsule Filter: Can be autoclaved 50 cycles for 30 min at 130 °C (Can not be steam sterilized in line)<br>Cleansteam Bag Sterile Package: Pre-sterilized by autoclave for 30 min at 121 °C      |

Notes: Gamma sterilized products cannot be re-sterilized with gamma irradiation or steam sterilization

## Flow Rates

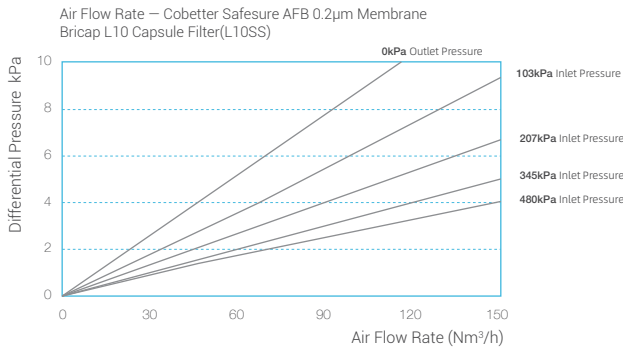
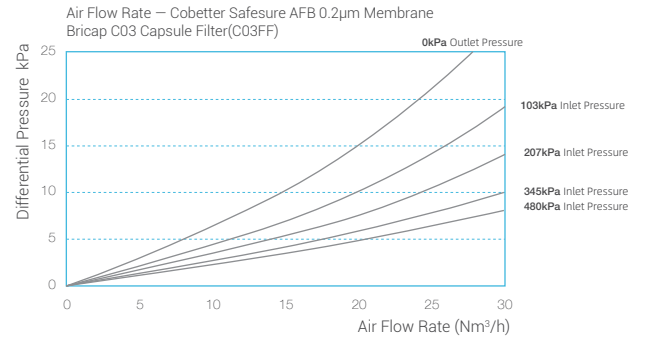
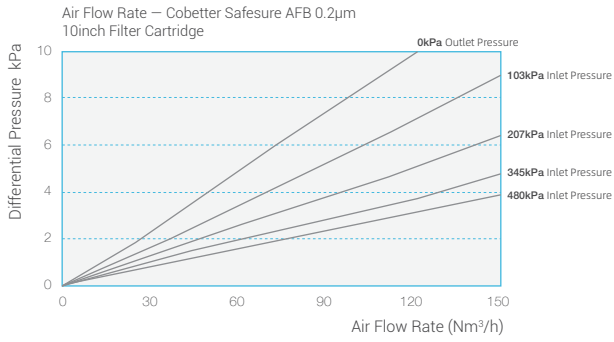

## Regulatory Compliance

- Effluent meets the USP<788> requirement of particulate matter in large volume injection.
- Component materials meet the criteria for a "Non-fiber-releasing filter" as defined in 21 CFR 210.3(b)(6).
- Retention of  $10^7$  cfu/cm<sup>2</sup> *Brevundimonas diminuta* (ATCC 19146) according to ASTM F838
- Typical Log Reduction Value (LRV) >7 using  $>10^8$  pfu *Bacteriophage Phi-X174* (ATCC 13706-B1)
- Aqueous extraction from a cartridge contains less than 0.25EU/ml as determined by Limulus Amebocyte Lysate (LAL), meeting requirements of USP<85>.
- Components meet the requirement of USP <87> In Vitro Biological Reactivity Test.
- Components meet the criteria of the USP <88> Biological Reactivity Test for Class V-121 °C plastics.
- Components meet the FDA indirect Food Additive requirements cited in 21 CFR177-182.
- Based on the current information from our suppliers, all components used in the manufacture of this product are animal-free.

Notes: Contact Cobetter for more specification details.



# Safesure AFM Filter

## Hydrophobic Sterilizing-Grade Filter with High Retention Rate and High Throughput



### Features

- Inherently hydrophobic membrane
- High retention rate
- High throughput and low pressure differential
- Reliable retention of bacteria and particles

### Typical Applications

- Vent filter for fermentation, storage tanks
- Sterile filtration for compressed air, oxygen, nitrogen
- Single-use system application

### Quality Control

- 100% integrity testing in manufacturing
- Each filter is fully traceable with unique serial number
- ISO 9001:2015 manufacturing facility

### Removal Rating and Effective Filtration Area

|                              | AFMB(0.2µm)         |
|------------------------------|---------------------|
| A - Standard Cartridge (10") | 0.68 m <sup>2</sup> |

### Materials of Construction

|                           |  |
|---------------------------|--|
| Membrane                  | Hydrophobic Polytetrafluoroethylene (PTFE)                   |
| Support                   | Polypropylene (PP)   |
| Core/Cage/End Caps        | Polypropylene (PP)   |
| Cartridge End Cap Inserts | Polybutylene terephthalate (PBT)(Cartridges Only)            |
| Cartridge End Cap O-rings | Silicone / EPDM / Fluoroelastomer / PFA encapsulated O-rings |
| Capsule Housing           | Polypropylene (PP)   |
| Capsule Vent O-rings      | Silicone   |
| SP3 Capsule Port Insert   | 316L Stainless Steel   |
| SP3 Capsule Housing       | Polyetherimide (PEI)   |
| SP3 Capsule O-rings       | Silicone   |

### Maximum Differential Pressure

|                        |   |
|------------------------|---|
| A - Standard Cartridge | Forward: 0.69 MPa @ 25 °C, 0.40 MPa @ 60 °C, 0.24 MPa @ 80 °C |
|                        | Reverse: 0.30 MPa @ 25 °C, 0.10 MPa @ 80 °C                   |
| Capsule                | Forward: 0.55 MPa @ 25 °C, 0.1 MPa @ 80 °C                    |
|                        | Reverse: 0.21 MPa @ 25 °C                                     |

### Integrity Test Standards

|   |   |
|---|---|
| Standard - 10inch (0.68m <sup>2</sup> ) | Bubble Point@20°C: ≥0.11MPa, wetted with 60% IPA 40% water            |
|   | Air Diffusion@20°C: ≤24ml/min@0.095Mpa, wetted with 60% IPA 40% water |
|   | Water Flow Test@20°C: ≤0.75ml/min@0.25MPa                             |

### Sterilization

|                        |  |
|------------------------|--|
| A - Standard Cartridge | Can be steam sterilized for 30 minutes at 145 °C in forward direction(<30kPa) with 100 cycles plus in reverse direction(<10kPa), 150 cycles in total.<br>Can be autoclaved 200 cycles for 30 min at 130 °C |
| Capsule                | Autoclavable Capsule Filter: Can be autoclaved 50 cycles for 30 min at 130 °C (Can not be steam sterilized in line)<br>Cleansteam Bag Sterile Package: Pre-sterilized by autoclave for 30 min at 121 °C    |

Notes: Gamma sterilized products cannot be re-sterilized with gamma irradiation or steam sterilization

## Flow Rates

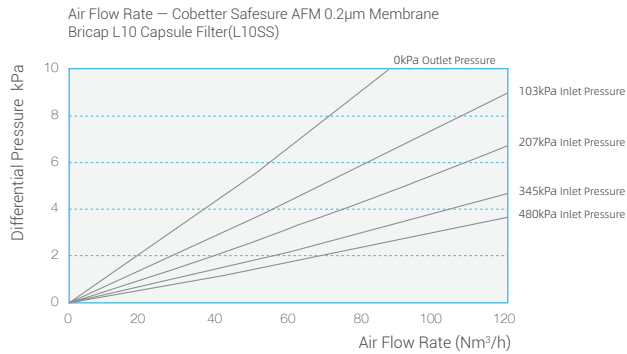
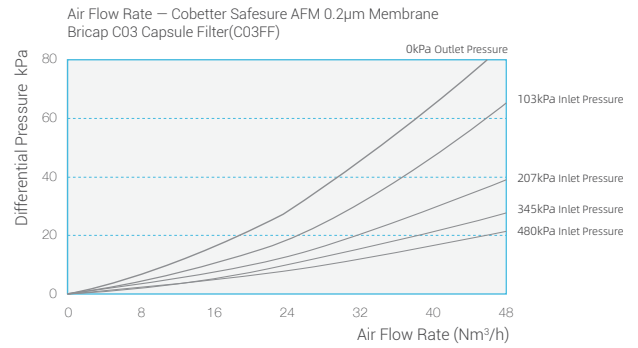
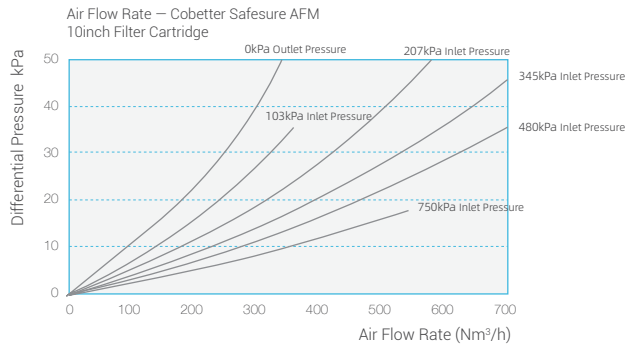

## Regulatory Compliance

- Effluent meets the USP<788> requirement of particulate matter in large volume injection.
- Component materials meet the criteria for a "Non-fiber-releasing filter" as defined in 21 CFR 210.3(b)(6).
- Retention of  $10^7$  cfu/cm<sup>2</sup> *Brevundimonas diminuta* (ATCC 19146) according to ASTM F838
- Typical Log Reduction Value (LRV) >7 using  $>10^8$  pfu *Bacteriophage Phi-X174* (ATCC 13706-B1)
- Aqueous extraction from a cartridge contains less than 0.25EU/ml as determined by Limulus Amebocyte Lysate (LAL), meeting requirements of USP<85>.
- Components meet the requirement of USP <87> In Vitro Biological Reactivity Test.
- Components meet the criteria of the USP <88> Biological Reactivity Test for Class V-121 °C plastics.
- Components meet the FDA indirect Food Additive requirements cited in 21 CFR 177-182.
- Based on the current information from our suppliers, all components used in the manufacture of this product are animal-free.

Notes: Contact Cobetter for more specification details.

## Safesure AFM Filter

### Ordering Information

#### Filter Cartridge



Cartridge Format

**A** Standard Cartridge



Membrane Type

**AFMB** AFM 0.2µm



Length

**02** 2.5 inch  
**05** 5 inch  
**10** 10 inch  
**20** 20 inch  
**30** 30 inch  
**40** 40 inch



Code

**0** DOE  
**2** 226 / Flat  
**7** 226 / Fin  
**3** 222 / Flat  
**8** 222 / Fin  
**6** 222 / 3-Flange bayonet / Fin



O-ring Material

**S** Silicone  
**E** EPDM  
**V** Fluoroelastomer  
**P** FEP/PFA encapsulated O-rings



Pharmaceutical Grade

#### Bricap C Series Capsule Filter



Housing Type

**Blank** Standard  
**K** Transparent



Capsule Format

**C01** Bricap C01  
**C02** Bricap C02  
**C03** Bricap C03



Inlet/Outlet

**T** 19 mm (3/4") Sanitary Flange  
**K** 14 mm (9/16") Sanitary Flange  
**F** 31 mm (1 1/4") Sanitary Flange  
**V** 14 mm (9/16") Hose Barb  
**H** 13 mm (1/2") Hose Barb  
**Y** 9.6 mm (3/8") Hose Barb  
**L** 3.2 mm (1/8") Hose Barb  
**B** 6-13 mm (1/4"-1/2") Stepped Hose Barb (No Filling Bell)

#### Bricap D Series Capsule Filter



Capsule Format

**D01** Bricap D01



Inlet/Outlet

**B** 6-13 mm (1/4"-1/2") Stepped Hose Barb (No Filling Bell)  
**A** 6-13 mm (1/4"-1/2") Stepped Hose Barb with Filling Bell (Outlet only)



Membrane Type

**AFMB** AFM 0.2µm



Sterilization

**A** Autoclavable  
**C** Sterile Package



Quantity/Package

**1** 1 /pkg



Pharmaceutical Grade

### Bricap L Series Capsule Filter



Housing Type

- Blank** Standard
- K** Transparent



Capsule Format

- L02** Bricap L02
- L03** Bricap L03
- L05** Bricap L05
- L10** Bricap L10
- L20** Bricap L20
- L30** Bricap L30



Inlet/Outlet

- S** 38 mm (1 1/2") Sanitary Flange
- T** 19 mm (3/4") Sanitary Flange
- K** 14 mm (9/16") Sanitary Flange
- D** 25 mm (1") Hose Barb
- M** 19 mm (3/4") Hose Barb
- X** 16 mm (5/8") Hose Barb
- V** 14 mm (9/16") Hose Barb
- H** 13 mm (1/2") Hose Barb
- Y** 9.6 mm (3/8") Hose Barb

### Bricap T Series Capsule Filter



Capsule Format

- T10** Bricap T10
- T20** Bricap T20
- T30** Bricap T30



Inlet/Outlet

- SS** 38 mm (1 1/2") Sanitary Flange Inlet & Outlet
- SM** 38 mm (1 1/2") Sanitary Flange Inlet & 19 mm (3/4") Hose Barb Outlet



Gauge Port Type

- S** 38 mm (1 1/2") Sanitary Flange
- T** 19 mm (3/4") Sanitary Flange
- N** Without Gauge Port

### Brisip SP3 Series Capsule Filter



Capsule Format

- SP3** Brisip SP3



Inlet/Outlet

- S** 38 mm (1 1/2") Sanitary Flange



Membrane Type

- AFMB** AFM 0.2µm



Vent and Drain Valves

- P** Both using 6 mm hose barb
- X** Vent valve using quick coupling (compatible with Stäubli connector), and drain valve using 6 mm hose barb
- T** Both using quick coupling (compatible with Stäubli connector)



Quantity/Package

- 1** 1 /pkg



Pharmaceutical Grade

Membrane Type

- AFMB** AFM 0.2µm

Sterilization

- A** Autoclavable

Quantity/Package

- 1** 1 /pkg

Pharmaceutical Grade

- P**



## Gas Filtration Series

# Aegivast ACE Filter

## Hydrophobic Filter with High Retention Rate



### Features

Inherently hydrophobic membrane  
 High retention rate  
 Low differential pressure  
 Reliable retention of bacteria and particles  
 Gamma irradiation compatible

### Typical Applications

Vent filter for fermentation, storage tanks  
 Sterilizing for compress air, oxygen, nitrogen etc.  
 Used in single-use system

### Quality Control

100% integrity testing in manufacturing  
 Each filter is fully traceable with unique serial number  
 ISO 9001:2015 manufacturing facility

### Removal Rating and Effective Filtration Area

| Membrane Type   | ACEB                 | ACEB                | ACEB                | ACEB              | ACEB                 | ACEB               | ACEB               |
|-----------------|----------------------|---------------------|---------------------|-------------------|----------------------|--------------------|--------------------|
| Removal Ratings | 0.2 µm               | 0.2 µm              | 0.2 µm              | 0.2 µm            | 0.2 µm               | 0.2 µm             | 0.2 µm             |
| Format          | U13                  | U25                 | U33                 | V37               | V42                  | V5A                | V5D                |
| Filtration Area | 0.72 cm <sup>2</sup> | 3.4 cm <sup>2</sup> | 4.5 cm <sup>2</sup> | 7 cm <sup>2</sup> | 13.8 cm <sup>2</sup> | 20 cm <sup>2</sup> | 20 cm <sup>2</sup> |

### Material of Construction

|          |   |
|----------|---|
| Membrane | Hydrophobic Polytetrafluoroethylene (PTFE)            |
| Support  | Polyester(Code S and Code G) or Polypropylene(Code A) |
| Housing  | Polypropylene (PP)                                    |

### Maximum Pressure Differential

|     |                          |     |                          |
|-----|--------------------------|-----|--------------------------|
| U13 | Forward: 0.6 MPa @ 25 °C | V37 | Forward: 0.24 MPa @25 °C |
| U25 | Forward: 0.3 MPa @ 25 °C | V42 | Forward: 0.24 MPa @25 °C |
| U33 | Forward: 0.2 MPa @ 25 °C | V5A | Forward: 0.24 MPa @25 °C |
|     |                          | V5D | Forward: 0.42 MPa @25 °C |

### Integrity Test Standards

|                       |   |
|-----------------------|---|
| U13 & U25 & U33       | Bubble Point@20: ≥0.11MPa, wetted with 60% IPA 40% water, air |
| V37 & V42 & V5A & V5D | Bubble Point@20: ≥0.11MPa, wetted with 60% IPA 40% water, air |

### Sterilization

|                                 |   |
|---------------------------------|---|
| Gamma-Compatible Syringe Filter | Can be sterilized by gamma irradiation at 25-45kGy<br>Can be autoclaved for 20 cycles of 30min at 134 °C(Can not be steam sterilized in line) |
| Sterile Syringe Filter          | Pre-sterilized by gamma irradiation at 25-45kGy, can not be re-sterilized   |

### Sterilization

|                               |  |
|-------------------------------|--|
| Gamma-Compatible Vent Filter  | Can be sterilized by gamma irradiation at 25-45kGy<br>Or can be autoclaved for 20 cycles of 30min at 134°C (Can not be steam sterilized in line) |
| Sterile Vent Disc Filter      | Pre-sterilized by gamma irradiation at 25-45kGy, can not be re-sterilized  |
| Autoclavable Vent Disc Filter | Can be autoclaved for 20 cycles of 30min at 130°C (Can not be steam sterilized in line)  |

## Flow Rates

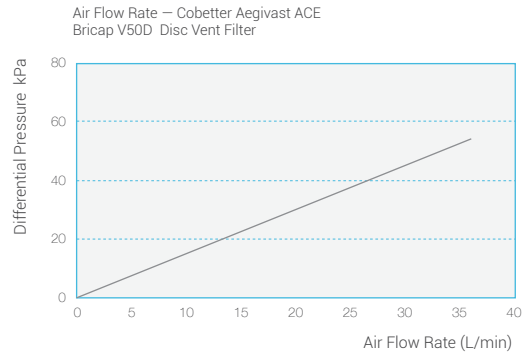
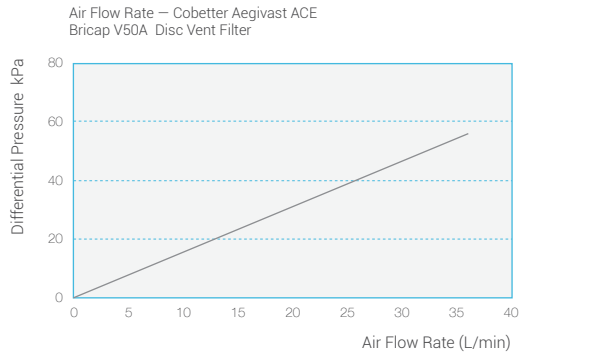
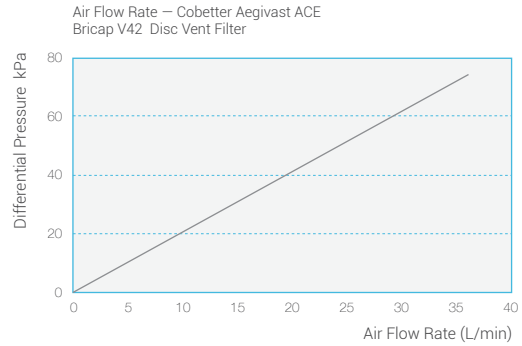
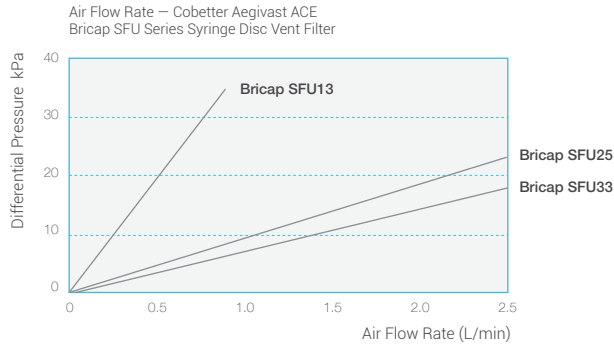

## Regulatory Compliance

- Effluent meets the USP<788> requirement of particulate matter in large volume injection.
- Component materials meet the criteria for a "Non-fiber-releasing filter" as defined in 21 CFR 210.3(b)(6).
- Retention of  $10^7$  cfu/cm<sup>2</sup> *Brevundimonas diminuta* (ATCC 19146) according to ASTM F838
- Aqueous extraction from a cartridge contains less than 0.25EU/ml as determined by Limulus Amebocyte Lysate (LAL), meeting requirements of USP<85>.
- Components meet the requirement of USP <87> In Vitro Biological Reactivity Test.
- Components meet the criteria of the USP <88> Biological Reactivity Test for Class V-121 °C plastics.
- Components meet the FDA indirect Food Additive requirements cited in 21 CFR177-182.
- Based on the current information from our suppliers, all components used in the manufacture of this product are animal-free.

Notes: Contact Cobetter for more specification details.

## Aegivast ACEB Filter

### Ordering Information

#### Bricap SFU Series Syringe Filter



Syringe Filter Format

- U13** Bricap SFU13
- U25** Bricap SFU25
- U33** Bricap SFU33



Inlet/Outlet

- CP** Female luer lock inlet and male luer lock outlet

#### Bricap V Series Syringe Filter



Vent Disc Filter Format

- V37** Bricap V37
- V42** Bricap V42
- V5A** Bricap V50A
- V5D** Bricap V50D



Inlet/Outlet

- EE** 6-9 mm (1/4"-3/8") Stepped Hose Barb Inlet and Outlet( Only Bricap V37 & V42)
- BB** 6-13 mm (1/4"-1/2") Stepped Hose Barb Inlet and Outlet



Membrane Type

- ACEB** ACE 0.2µm



Sterilization

- A** Autoclavable
- G** Gamma Compatible
- S** Sterile



Quantity/Package

- 1** 1 /pkg



Pharmaceutical Grade

## Clarification Filter Series

# Excesal CHT Filter

## Clarification Filter with High Dirt-Holding Capacity



### Features

Gradient pore structure to significantly enhance dirt-holding capacity  
 A multi-layer structure with increasing precision  
 Capable of graded particle retention, extending the filter's service time  
 Great particle retention efficiency

### Typical Applications

Fermentation broth  
 Pre-filtration blood products/serums  
 Pre-filtration of colloids/viscous liquids

### Quality Control

100% integrity testing in manufacturing  
 Each filter is fully traceable with unique serial number  
 ISO 9001:2015 manufacturing facility

### Removal Rating and Effective Filtration Area

|                              | CHT(0.2µm)         | CHT(0.5µm)         | CHT(1.0µm)         | CHT(2.0µm)         | CHT(5.0µm)         | CHT1X(10µm)        | CHT2X(20µm)        | CHT7X(70µm)        |
|------------------------------|--------------------|--------------------|--------------------|--------------------|--------------------|--------------------|--------------------|--------------------|
| A - Standard Cartridge (10") | 0.20m <sup>2</sup> | 0.28m <sup>2</sup> | 0.25m <sup>2</sup> | 0.25m <sup>2</sup> | 0.25m <sup>2</sup> | 0.25m <sup>2</sup> | 0.28m <sup>2</sup> | 0.28m <sup>2</sup> |

### Materials of Construction

|                            |  |
|----------------------------|--|
| Membrane                   | Polypropylene (PP)   |
| Support/Core/Cage/End Caps | Polypropylene (PP)   |
| End Cap Inserts            | Polybutylene terephthalate (PBT) (Cartridge Exclusive)       |
| O-rings                    | Silicone / EPDM / Fluoroelastomer / PFA encapsulated O-rings |
| Capsule Housing            | Polypropylene (PP)   |
| Capsule Vent O-rings       | Silicone   |

### Maximum Differential Pressure

|                        |  |
|------------------------|--|
| A - Standard Cartridge | Forward : 0.69 MPa @ 25 °C, 0.40 MPa @ 60 °C, 0.24 MPa @ 80 °C<br>Reverse : 0.30 MPa @ 25 °C, 0.10 MPa @ 80 °C |
| Capsule                | Forward : 0.55 MPa @ 25 °C, 0.1 MPa @ 80 °C<br>Reverse : 0.21 MPa @ 25 °C                                      |

### Particle Retention Rates(%)

| Filter | 1.0µm  | 2.0µm  | 5.0µm  | 10µm   | 20µm   | 40µm   | 70µm   |
|--------|--------|--------|--------|--------|--------|--------|--------|
| CHT02  | ≥99.90 | ≥99.90 | ≥99.90 | ≥99.99 | ≥99.99 | ≥99.99 | ≥99.99 |
| CHT05  | ≥99.00 | ≥99.50 | ≥99.90 | ≥99.90 | ≥99.99 | ≥99.99 | ≥99.99 |
| CHT10  | ≥98.00 | ≥99.00 | ≥99.50 | ≥99.90 | ≥99.98 | ≥99.99 | ≥99.99 |
| CHT20  | —      | ≥98.00 | ≥99.00 | ≥99.50 | ≥99.90 | ≥99.98 | ≥99.99 |
| CHT50  | —      | —      | ≥98.00 | ≥99.00 | ≥99.50 | ≥99.90 | ≥99.98 |
| CHT1X  | —      | —      | —      | ≥98.00 | ≥99.00 | ≥99.50 | ≥99.90 |
| CHT2X  | —      | —      | —      | —      | ≥98.00 | ≥99.00 | ≥99.50 |
| CHT4X  | —      | —      | —      | —      | —      | ≥98.00 | ≥99.00 |
| CHT7X  | —      | —      | —      | —      | —      | —      | ≥98.00 |

## Sterilization

|                        |  |
|------------------------|--|
| A - Standard Cartridge | Can be steam sterilized for 30 minutes at 125 °C with 20 cycles (< 30 kPa)<br>Can be autoclaved 20 cycles for 30 minutes at 125°C  |
| Capsule                | Autoclavable capsules only: Can be autoclaved 20 cycles for 30 minutes at 125°C, (Can not be steam sterilized in-line)<br>Gamma compatible capsules: Can be sterilized by gamma irradiation at 25-45 kGy or can be autoclaved 5 cycles for 60 minutes at 126 °C. (Can not be steamed in-line)<br>Sterile capsule: Products that have been gamma-sterilized cannot be re-sterilized using gamma irradiation or steam sterilization<br>Cleansteam bag sterile package: Pre-sterilized with autoclave for 30 minutes at 121°C |

Notes: Gamma sterilized products cannot be re-sterilized with gamma irradiation or steam sterilization

## Flow Rates

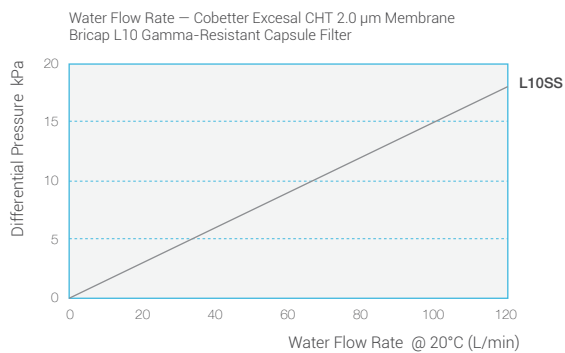
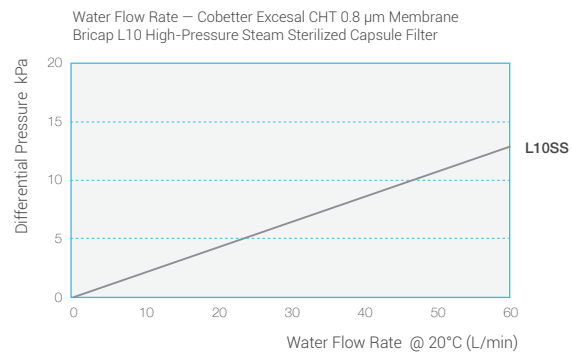
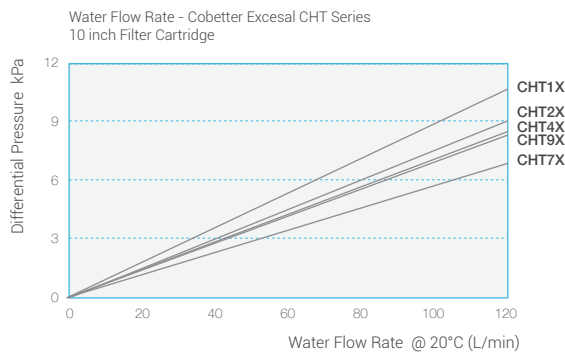
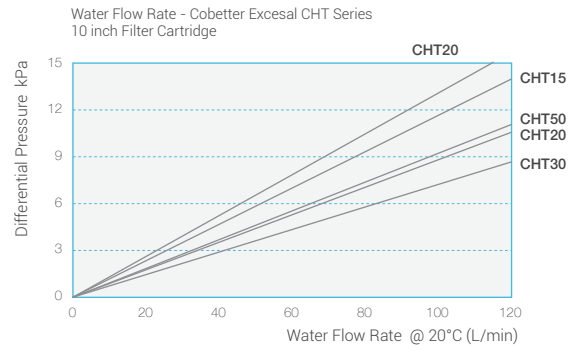
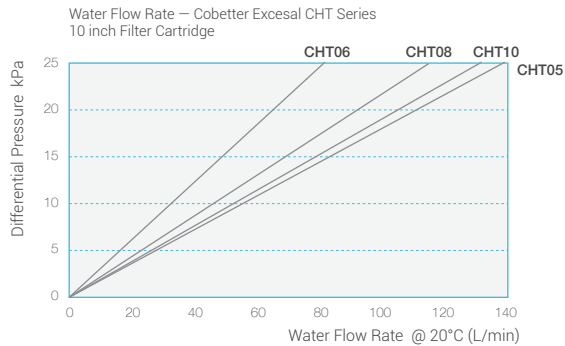

## Regulatory Compliance







- Effluent meets the USP<788> requirement of particulate matter in large volume injection.
- Component materials meet the criteria for a "Non-fiber-releasing filter" as defined in 21 CFR 210.3(b)(6).
- Aqueous extraction from a cartridge contains less than 0.25EU/ml as determined by Limulus Amebocyte Lysate (LAL), meeting requirements of USP<85>.
- Components meet the requirement of USP <87> In Vitro Biological Reactivity Test.
- Components meet the criteria of the USP <88> Biological Reactivity Test for Class V-121 °C plastics.
- Components meet the FDA indirect Food Additive requirements cited in 21 CFR 177-182.
- Based on the current information from our suppliers, all components used in the manufacture of this product are animal-free.

Notes: Contact Cobetter for more specification details.







# Cobetter Excesal CHT Filter

## Ordering Information



### Filter Cartridge

|  |  |  |   |   |   |
|--|--|--|---|---|---|
|  |   |                     |    |                      |  |
| Cartridge Format   | Membrane Type  | Length   | Code  | O-ring Material   | Pharmaceutical Grade  |
| <b>A</b> Standard Cartridge  | <b>CHT02</b> CHT 0.2 µm<br><b>CHT05</b> CHT 0.5 µm<br><b>CHT06</b> CHT 0.6 µm<br><b>CHT08</b> CHT 0.8 µm<br><b>CHT10</b> CHT 1.0 µm<br><b>CHT15</b> CHT 1.5 µm<br><b>CHT20</b> CHT 2.0 µm<br><b>CHT50</b> CHT 5.0 µm<br><b>CHT1X</b> CHT 10 µm<br><b>CHT2X</b> CHT 20 µm<br><b>CHT4X</b> CHT 40 µm<br><b>CHT7X</b> CHT 70 µm<br><b>CHT9X</b> CHT 90 µm | <b>05</b> 5 inch<br><b>10</b> 10 inch<br><b>20</b> 20 inch<br><b>30</b> 30 inch<br><b>40</b> 40 inch | <b>0</b> DOE<br><b>2</b> 226 / Flat<br><b>7</b> 226 / Fin<br><b>3</b> 222 / Flat<br><b>8</b> 222 / Fin<br><b>6</b> 222 / 3-Flange bayonet / Fin | <b>S</b> Silicone<br><b>E</b> EPDM<br><b>V</b> Fluoroelastomer<br><b>P</b> FEP/PFA encapsulated O-rings |   |



### Bricap C Series Capsule Filter

|  |   |   |  |   |   |   |
|--|---|---|--|---|---|---|
|  |  |    |   |                                |  |  |
| Housing Type   | Capsule Format  | Inlet/Outlet  | Membrane Type  | Sterilization   | Quantity/Package  | Pharmaceutical Grade  |
| <b>Blank</b> Standard<br><b>K</b> Transparent                                    | <b>C03</b> Bricap C03   | <b>T</b> 19 mm (3/4") Sanitary Flange<br><b>K</b> 14 mm (9/16") Sanitary Flange<br><b>F</b> 31 mm (1 1/4") Sanitary Flange<br><b>V</b> 14 mm (9/16") Hose Barb<br><b>H</b> 13 mm (1/2") Hose Barb<br><b>Y</b> 9.6 mm (3/8") Hose Barb<br><b>L</b> 3.2 mm (1/8") Hose Barb<br><b>B</b> 6-13 mm (1/4"-1/2") Stepped Hose Barb (No Filling Bell)<br><b>A</b> 6-13 mm (1/4"-1/2") Stepped Hose Barb with Filling Bell (Outlet only) | <b>CHT02</b> CHT 0.2 µm<br><b>CHT05</b> CHT 0.5 µm<br><b>CHT06</b> CHT 0.6 µm<br><b>CHT08</b> CHT 0.8 µm<br><b>CHT10</b> CHT 1.0 µm<br><b>CHT15</b> CHT 1.5 µm<br><b>CHT20</b> CHT 2.0 µm<br><b>CHT50</b> CHT 5.0 µm<br><b>CHT1X</b> CHT 10 µm<br><b>CHT2X</b> CHT 20 µm<br><b>CHT4X</b> CHT 40 µm<br><b>CHT7X</b> CHT 70 µm<br><b>CHT9X</b> CHT 90 µm | <b>A</b> Autoclavable<br><b>G</b> Gamma Compatible<br><b>S</b> Sterile<br><b>C</b> Cleansteam Bag Sterile Package | <b>1</b> 1 /pkg   |   |



### Bricap D Series Capsule Filter





|  |  |
|--|--|
|  |   |
| Capsule Format   | Inlet/Outlet   |
| <b>D01</b> Bricap D01  | <b>B</b> 6-13 mm (1/4"-1/2") Stepped Hose Barb (No Filling Bell)<br><b>A</b> 6-13 mm (1/4"-1/2") Stepped Hose Barb with Filling Bell (Outlet only) |

### Bricap L Series Capsule Filter

|  |  |  |
|--|--|--|
|  |   |   |
| Housing Type   | Capsule Format   | Inlet/Outlet   |
| <b>Blank</b> Standard<br><b>K</b> Transparent                                      | <b>L02</b> Bricap L02<br><b>L03</b> Bricap L03<br><b>L05</b> Bricap L05<br><b>L10</b> Bricap L10<br><b>L20</b> Bricap L20<br><b>L30</b> Bricap L30 | <b>S</b> 38 mm (1 1/2") Sanitary Flange<br><b>T</b> 19 mm (3/4") Sanitary Flange<br><b>K</b> 14 mm (9/16") Sanitary Flange<br><b>D</b> 25 mm (1") Hose Barb<br><b>M</b> 19 mm (3/4") Hose Barb<br><b>X</b> 16 mm (5/8") Hose Barb<br><b>V</b> 14 mm (9/16") Hose Barb<br><b>H</b> 13 mm (1/2") Hose Barb<br><b>Y</b> 9.6 mm (3/8") Hose Barb |

### Bricap T Series Capsule Filter

|  |   |   |
|--|---|---|
|  |    |                              |
| Capsule Format   | Inlet/Outlet  | Gauge Port Type   |
| <b>T10</b> Bricap T10<br><b>T20</b> Bricap T20<br><b>T30</b> Bricap T30            | <b>SS</b> 38 mm (1 1/2") Sanitary Flange Inlet & Outlet<br><b>SM</b> 38 mm (1 1/2") Sanitary Flange Inlet & 19 mm (3/4") Hose Barb Outlet | <b>S</b> 38 mm (1 1/2") Sanitary Flange<br><b>T</b> 19 mm (3/4") Sanitary Flange<br><b>N</b> Without Gauge Port |

|  |   |   |   |
|--|---|---|---|
|   |                                |  |  |
| Membrane Type  | Sterilization   | Quantity/Package  | Pharmaceutical Grade  |
| <b>CHT02</b> CHT 0.2 µm<br><b>CHT05</b> CHT 0.5 µm<br><b>CHT06</b> CHT 0.6 µm<br><b>CHT08</b> CHT 0.8 µm<br><b>CHT10</b> CHT 1.0 µm<br><b>CHT15</b> CHT 1.5 µm<br><b>CHT20</b> CHT 2.0 µm<br><b>CHT50</b> CHT 5.0 µm<br><b>CHT1X</b> CHT 10 µm<br><b>CHT2X</b> CHT 20 µm<br><b>CHT4X</b> CHT 40 µm<br><b>CHT7X</b> CHT 70 µm<br><b>CHT9X</b> CHT 90 µm | <b>A</b> Autoclavable<br><b>G</b> Gamma Compatible<br><b>S</b> Sterile<br><b>C</b> Cleansteam Bag Sterile Package | <b>1</b> 1 /pkg   |   |

## Clarification Filter Series

# Excesal CHE Filter

## Clarification Filter with High Retention Rate



### Features

Inner layer uses nanofibers for high retention rate  
 Double-layer structure with increasing precision  
 High dirt-holding capacity and long service time

### Typical Applications

Fermentation broth  
 Pre-filtration blood products/serums  
 Pre-filtration of colloids/viscous liquids

### Quality Control

100% integrity testing in manufacturing  
 Each filter is fully traceable with unique serial number  
 ISO 9001:2015 manufacturing facility

### Removal Rating and Effective Filtration Area

|                              | CHE(0.2µm)         | CHE(0.3µm)         | CHE(0.5µm)         | CHE(0.65µm)        | CHE(0.8µm)         | CHE(1.0µm)         | CHE(3.0µm)         | CHE(5.0µm)         |
|------------------------------|--------------------|--------------------|--------------------|--------------------|--------------------|--------------------|--------------------|--------------------|
| A - Standard Cartridge (10") | 0.48m <sup>2</sup> | 0.39m <sup>2</sup> | 0.41m <sup>2</sup> | 0.52m <sup>2</sup> | 0.55m <sup>2</sup> | 0.52m <sup>2</sup> | 0.52m <sup>2</sup> | 0.57m <sup>2</sup> |

### Materials of Construction

|                      |   |
|----------------------|---|
| Membrane             | Polypropylene (PP)  |
| Support              | Polypropylene (PP)  |
| Core/Cage/End Caps   | Polybutylene terephthalate (PBT)<br>(Cartridge exclusive)       |
| O-ring               | Silicone / EPDM / Fluoroelastomer /<br>PFA encapsulated O-rings |
| Capsule Housing      | Polypropylene (PP)  |
| Capsule Vent O-rings | Silicone  |

### Maximum Differential Pressure

|                        |   |
|------------------------|---|
| A - Standard Cartridge | Forward: 0.69 MPa @ 25 °C, 0.40 MPa @ 60 °C, 0.24 MPa @ 80 °C |
|                        | Reverse: 0.30 MPa @ 25 °C, 0.10 MPa @ 80 °C                   |
| Capsule                | Forward: 0.55 MPa @ 25 °C, 0.1 MPa @ 80 °C                    |
|                        | Reverse: 0.21 MPa @ 25 °C                                     |

### Particle Retention Rates(%)

| Filter     | 1.0µm  | 3.0µm  | 4.0µm  | 5.0µm  | 6.0µm  | 7.0µm  | 10µm   | 20µm   |
|------------|--------|--------|--------|--------|--------|--------|--------|--------|
| CHE 0.2µm  | ≥99.99 | ≥99.99 | ≥99.99 | ≥99.99 | ≥99.99 | ≥99.99 | ≥99.99 | ≥99.99 |
| CHE 0.3µm  | ≥99.98 | ≥99.99 | ≥99.99 | ≥99.99 | ≥99.99 | ≥99.99 | ≥99.99 | ≥99.99 |
| CHE 0.5µm  | ≥99.90 | ≥99.98 | ≥99.99 | ≥99.99 | ≥99.99 | ≥99.99 | ≥99.99 | ≥99.99 |
| CHE 0.65µm | ≥99.50 | ≥99.90 | ≥99.98 | ≥99.99 | ≥99.99 | ≥99.99 | ≥99.99 | ≥99.99 |
| CHE 0.8µm  | ≥99.20 | ≥99.50 | ≥99.90 | ≥99.98 | ≥99.99 | ≥99.99 | ≥99.99 | ≥99.99 |
| CHE 1.0µm  | ≥99.00 | ≥99.20 | ≥99.50 | ≥99.90 | ≥99.98 | ≥99.99 | ≥99.99 | ≥99.99 |
| CHE 3.0µm  | —      | ≥99.00 | ≥99.20 | ≥99.50 | ≥99.90 | ≥99.98 | ≥99.99 | ≥99.99 |
| CHE 5.0µm  | —      | —      | —      | ≥99.00 | ≥99.20 | ≥99.50 | ≥99.90 | ≥99.98 |

## Sterilization

|                        |  |
|------------------------|--|
| A - Standard Cartridge | Can be steam sterilized for 30 minutes at 125 °C with 20 cycles (< 30 kPa)<br>Can be autoclaved 20 cycles for 30 minutes at 125°C  |
| Capsule                | Autoclavable capsules only: Can be autoclaved 20 cycles for 30 minutes at 125°C, (Can not be steam sterilized in-line)<br>Cleansteam bag sterile package: Pre-sterilized with autoclave for 30 minutes at 121 °C |

Notes: Gamma sterilized products cannot be re-sterilized with gamma irradiation or steam sterilization

## Flow Rates

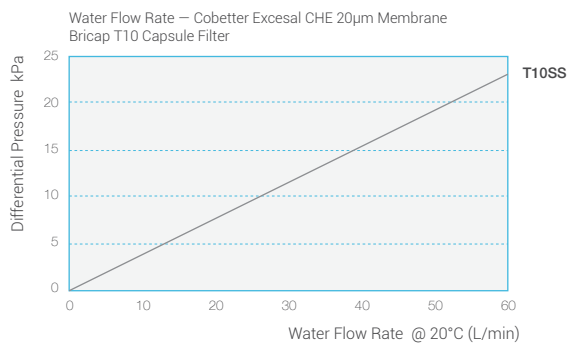
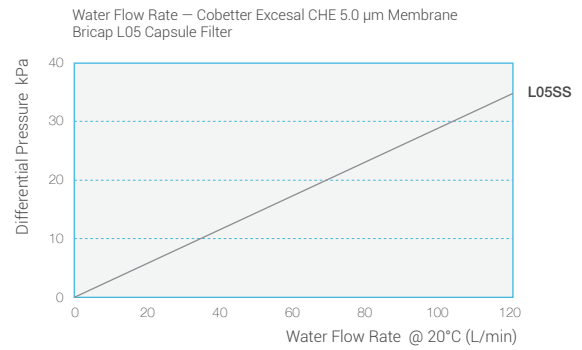
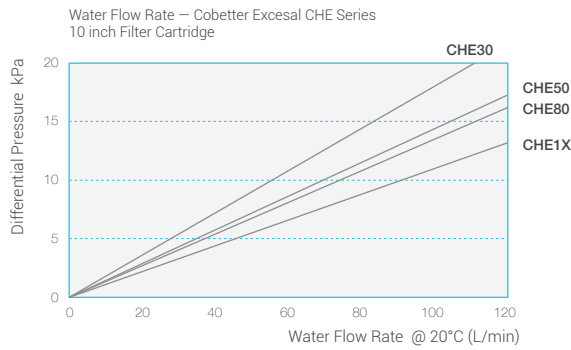
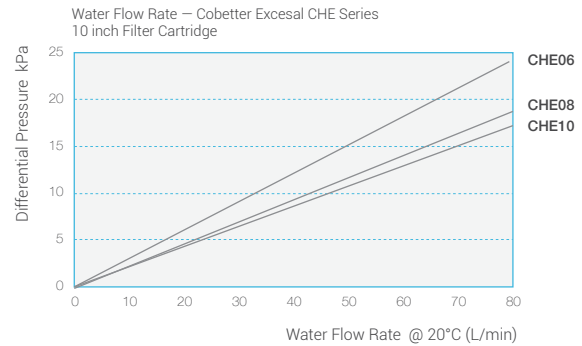
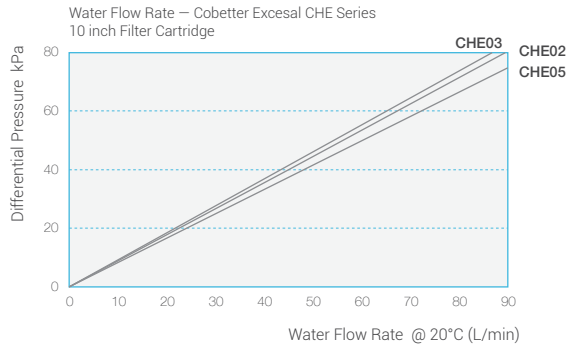

## Regulatory Compliance







- Effluent meets the USP<788> requirement of particulate matter in large volume injection.
- Component materials meet the criteria for a "Non-fiber-releasing filter" as defined in 21 CFR 210.3(b)(6).
- Aqueous extraction from a cartridge contains less than 0.25EU/ml as determined by Limulus Amebocyte Lysate (LAL), meeting requirements of USP<85>.
- Components meet the requirement of USP <87> In Vitro Biological Reactivity Test.
- Components meet the criteria of the USP <88> Biological Reactivity Test for Class V-121 °C plastics.
- Components meet the FDA indirect Food Additive requirements cited in 21 CFR 177-182.
- Based on the current information from our suppliers, all components used in the manufacture of this product are animal-free.

Notes: Contact Cobetter for more specification details.







## Cobetter Excesal CHE Filter

### Ordering Information



#### Filter Cartridge

|  |  |  |   |   |   |
|--|--|--|---|---|---|
|  |   |                     |    |                      |  |
| Cartridge Format   | Membrane Type  | Length   | Code  | O-ring Material   | Pharmaceutical Grade  |
| <b>A</b> Standard Cartridge  | <b>CHE02</b> CHE 0.2 µm<br><b>CHE03</b> CHE 0.3 µm<br><b>CHE05</b> CHE 0.5 µm<br><b>CHE06</b> CHE 0.65 µm<br><b>CHE08</b> CHE 0.8 µm<br><b>CHE10</b> CHE 1.0 µm<br><b>CHE30</b> CHE 3.0 µm<br><b>CHE50</b> CHE 5.0 µm<br><b>CHE80</b> CHE 8.0 µm<br><b>CHE1X</b> CHE 10 µm<br><b>CHE2X</b> CHE 20 µm | <b>05</b> 5 inch<br><b>10</b> 10 inch<br><b>20</b> 20 inch<br><b>30</b> 30 inch<br><b>40</b> 40 inch | <b>0</b> DOE<br><b>2</b> 226 / Flat<br><b>7</b> 226 / Fin<br><b>3</b> 222 / Flat<br><b>8</b> 222 / Fin<br><b>6</b> 222 / 3-Flange bayonet / Fin | <b>S</b> Silicone<br><b>E</b> EPDM<br><b>V</b> Fluoroelastomer<br><b>P</b> FEP/PFA encapsulated O-rings |   |



#### Bricap C Series Capsule Filter

|  |   |   |  |   |   |   |
|--|---|---|--|---|---|---|
|  |  |    |   |  |  |  |
| Housing Type   | Capsule Format  | Inlet/Outlet  | Membrane Type  | Sterilization   | Quantity/Package  | Pharmaceutical Grade  |
| <b>Blank</b> Standard<br><b>K</b> Transparent                                    | <b>C03</b> Bricap C03   | <b>T</b> 19 mm (3/4") Sanitary Flange<br><b>K</b> 14 mm (9/16") Sanitary Flange<br><b>F</b> 31 mm (1 1/4") Sanitary Flange<br><b>V</b> 14 mm (9/16") Hose Barb<br><b>H</b> 13 mm (1/2") Hose Barb<br><b>Y</b> 9.6 mm (3/8") Hose Barb<br><b>L</b> 3.2 mm (1/8") Hose Barb<br><b>B</b> 6-13 mm (1/4"-1/2") Stepped Hose Barb (No Filling Bell)<br><b>A</b> 6-13 mm (1/4"-1/2") Stepped Hose Barb with Filling Bell (Outlet only) | <b>CHE02</b> CHE 0.2 µm<br><b>CHE03</b> CHE 0.3 µm<br><b>CHE05</b> CHE 0.5 µm<br><b>CHE06</b> CHE 0.65 µm<br><b>CHE08</b> CHE 0.8 µm<br><b>CHE10</b> CHE 1.0 µm<br><b>CHE30</b> CHE 3.0 µm<br><b>CHE50</b> CHE 5.0 µm<br><b>CHE80</b> CHE 8.0 µm<br><b>CHE1X</b> CHE 10 µm<br><b>CHE2X</b> CHE 20 µm | <b>A</b> Autoclavable<br><b>C</b> Cleansteam Bag Sterile Package                    | <b>1</b> 1 /pkg   |   |



#### Bricap D Series Capsule Filter

|  |  |
|--|--|
|  |   |
| Capsule Format   | Inlet/Outlet   |
| <b>D01</b> Bricap D01  | <b>B</b> 6-13 mm (1/4"-1/2") Stepped Hose Barb (No Filling Bell)<br><b>A</b> 6-13 mm (1/4"-1/2") Stepped Hose Barb with Filling Bell (Outlet only) |

#### Bricap L Series Capsule Filter

|  |  |  |
|--|--|--|
|  |   |   |
| Housing Type   | Capsule Format   | Inlet/Outlet   |
| <b>Blank</b> Standard<br><b>K</b> Transparent                                      | <b>L02</b> Bricap L02<br><b>L03</b> Bricap L03<br><b>L05</b> Bricap L05<br><b>L10</b> Bricap L10<br><b>L20</b> Bricap L20<br><b>L30</b> Bricap L30 | <b>S</b> 38 mm (1 1/2") Sanitary Flange<br><b>T</b> 19 mm (3/4") Sanitary Flange<br><b>K</b> 14 mm (9/16") Sanitary Flange<br><b>D</b> 25 mm (1") Hose Barb<br><b>M</b> 19 mm (3/4") Hose Barb<br><b>X</b> 16 mm (5/8") Hose Barb<br><b>V</b> 14 mm (9/16") Hose Barb<br><b>H</b> 13 mm (1/2") Hose Barb<br><b>Y</b> 9.6 mm (3/8") Hose Barb |

#### Bricap T Series Capsule Filter

|  |   |   |
|--|---|---|
|  |    |                              |
| Capsule Format   | Inlet/Outlet  | Gauge Port Type   |
| <b>T10</b> Bricap T10<br><b>T20</b> Bricap T20<br><b>T30</b> Bricap T30            | <b>SS</b> 38 mm (1 1/2") Sanitary Flange Inlet & Outlet<br><b>SM</b> 38 mm (1 1/2") Sanitary Flange Inlet & 19 mm (3/4") Hose Barb Outlet | <b>S</b> 38 mm (1 1/2") Sanitary Flange<br><b>T</b> 19 mm (3/4") Sanitary Flange<br><b>N</b> Without Gauge Port |



## Clarification Filter Series

# Greclary CHV Filter High Throughput Filter



### Features

Fine glass fibers as the filtration medium  
Rigid fiber material, suitable for colloid filtration  
High dirt-holding capacity and high retention rate  
Low initial pressure drop, high flow rate,  
and long service time

### Typical Applications

Fermentation broth  
Pre-filtration blood products/serums  
Pre-filtration of colloids/viscous liquids

### Quality Control

100% integrity testing in manufacturing  
Each filter is fully traceable with unique serial number  
ISO 9001:2015 manufacturing facility

### Removal Rating and Effective Filtration Area

|                              | CHV(0.2µm)         | CHV(0.45µm)        | CHV(1.0µm)         | CHV10P(1.0µm)      |
|------------------------------|--------------------|--------------------|--------------------|--------------------|
| A - Standard Cartridge (10") | 0.28m <sup>2</sup> | 0.28m <sup>2</sup> | 0.28m <sup>2</sup> | 0.28m <sup>2</sup> |

### Materials of Construction

|                      |   |
|----------------------|---|
| Membrane             | Polypropylene (PP)  |
| Support              | Polypropylene (PP)  |
| Core/Cage/End Caps   | Polybutylene terephthalate (PBT)<br>(Cartridge exclusive)       |
| O-ring               | Silicone / EPDM / Fluoroelastomer /<br>PFA encapsulated O-rings |
| Capsule Housing      | Polypropylene (PP)  |
| Capsule Vent O-rings | Silicone  |

### Maximum Differential Pressure

|                        |   |
|------------------------|---|
| A - Standard Cartridge | Forward: 0.69 MPa @ 25 °C, 0.40 MPa @ 60 °C, 0.24 MPa @ 80 °C |
|                        | Reverse: 0.30 MPa @ 25 °C, 0.10 MPa @ 80 °C                   |
| Capsule                | Forward: 0.55 MPa @ 25 °C, 0.1 MPa @ 80 °C                    |
|                        | Reverse: 0.21 MPa @ 25 °C                                     |

### Particle Retention Rates(%)

| Filter | 1.0µm  | 3.0µm  | 5.0µm  | 10µm   | 20µm   |
|--------|--------|--------|--------|--------|--------|
| CHV02  | ≥99.99 | ≥99.99 | ≥99.99 | ≥99.99 | ≥99.99 |
| CHV04  | ≥99.92 | ≥99.98 | ≥99.99 | ≥99.99 | ≥99.99 |
| CHV10  | ≥99.00 | ≥99.20 | ≥99.90 | ≥99.99 | ≥99.99 |
| CHV10P | ≥99.00 | ≥99.20 | ≥99.90 | ≥99.99 | ≥99.99 |

### Sterilization

|                        |  |
|------------------------|--|
| A - Standard Cartridge | Can be steam sterilized for 30 minutes at 125 °C with 20 cycles (< 30 kPa)   |
|                        | Can be autoclaved 20 cycles for 30 minutes at 125°C  |
| Capsule                | Autoclavable capsules only. Can be autoclaved 20 cycles for 30 minutes at 125°C, (Can not be steam sterilized in-line) |
|                        | Cleansteam bag sterile package: Pre-sterilized with autoclave for 30 minutes at 121 °C                                 |

Notes: Gamma sterilized products cannot be re-sterilized with gamma irradiation or steam sterilization

## Flow Rates

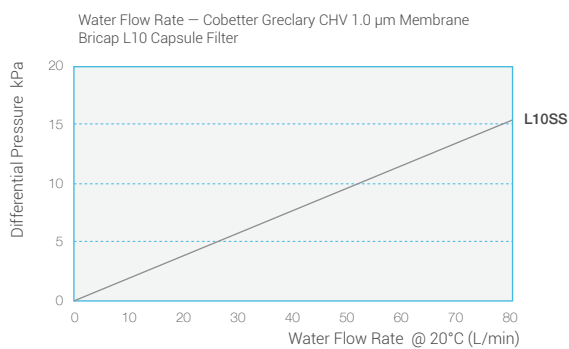
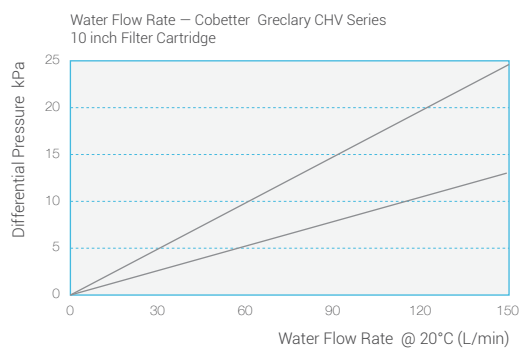
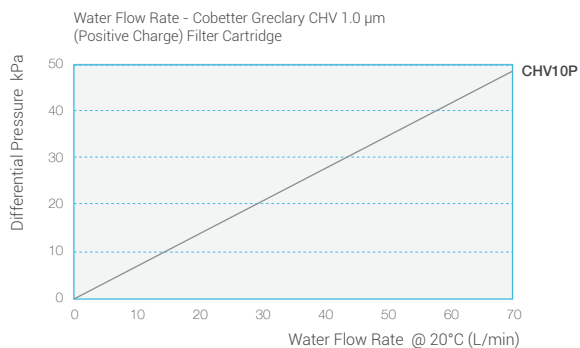
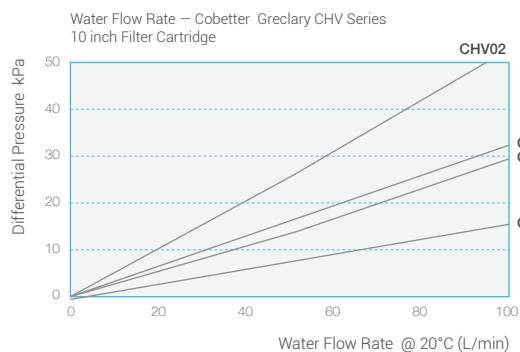

## Regulatory Compliance







- Effluent meets the USP<788> requirement of particulate matter in large volume injection.
- Component materials meet the criteria for a "Non-fiber-releasing filter" as defined in 21 CFR 210.3(b)(6).
- Aqueous extraction from a cartridge contains less than 0.25EU/ml as determined by Limulus Amebocyte Lysate (LAL), meeting requirements of USP<85>.
- Components meet the requirement of USP <87> In Vitro Biological Reactivity Test.
- Components meet the criteria of the USP <88> Biological Reactivity Test for Class V-121 °C plastics.
- Components meet the FDA indirect Food Additive requirements cited in 21 CFR 177-182.
- Based on the current information from our suppliers, all components used in the manufacture of this product are animal-free.

Notes: Contact Cobetter for more specification details.



## Cobetter Greclary CHV Filter

### Ordering Information



#### Filter Cartridge





|  |   |  |   |   |   |
|--|---|--|---|---|---|
|  |    |                     |    |                      |  |
| Cartridge Format   | Membrane Type   | Length   | Code  | O-ring Material   | Pharmaceutical Grade  |
| <b>A</b> Standard Cartridge  | <b>CHV02</b> CHV 0.2 µm<br><b>CHV04</b> CHV 0.45 µm<br><b>CHV06</b> CHV 0.65 µm<br><b>CHV08</b> CHV 0.8 µm<br><b>CHV10</b> CHV 1.0 µm<br><b>CHV10P</b> CHV 1.0 µm (Positive Charge)<br><b>CHV30</b> CHV 3.0 µm<br><b>CHV50</b> CHV 5.0 µm | <b>05</b> 5 inch<br><b>10</b> 10 inch<br><b>20</b> 20 inch<br><b>30</b> 30 inch<br><b>40</b> 40 inch | <b>0</b> DOE<br><b>2</b> 226 / Flat<br><b>7</b> 226 / Fin<br><b>3</b> 222 / Flat<br><b>8</b> 222 / Fin<br><b>6</b> 222 / 3-Flange bayonet / Fin | <b>S</b> Silicone<br><b>E</b> EPDM<br><b>V</b> Fluoroelastomer<br><b>P</b> FEP/PFA encapsulated O-rings |   |

#### Bricap C Series Capsule Filter



|  |   |  |
|--|---|--|
|  |  |   |
| Housing Type   | Capsule Format  | Inlet/Outlet   |
| <b>Blank</b> Standard<br><b>K</b> Transparent                                    | <b>C03</b> Bricap C03   | <b>T</b> 19 mm(3/4") Sanitary Flange<br><b>K</b> 14 mm (9/16") Sanitary Flange<br><b>F</b> 31 mm (1 1/4") Sanitary Flange<br><b>V</b> 14 mm (9/16") Hose Barb<br><b>H</b> 13 mm (1/2") Hose Barb<br><b>Y</b> 9.6 mm (3/8") Hose Barb<br><b>L</b> 3.2 mm (1/8") Hose Barb<br><b>B</b> 6-13 mm (1/4"-1/2") Stepped Hose Barb (No Filling Bell)<br><b>A</b> 6-13 mm (1/4"-1/2") Stepped Hose Barb with Filling Bell (Outlet only) |

#### Bricap D Series Capsule Filter



|  |  |
|--|--|
|  |   |
| Capsule Format   | Inlet/Outlet   |
| <b>D01</b> BricapD01   | <b>B</b> 6-13 mm (1/4"-1/2") Stepped Hose Barb (No Filling Bell)<br><b>A</b> 6-13 mm (1/4"-1/2") Stepped Hose Barb with Filling Bell (Outlet only) |





|   |   |   |   |
|---|---|---|---|
|    |  |  |  |
| Membrane Type   | Sterilization   | Quantity/Package  | Pharmaceutical Grade  |
| <b>CHV02</b> CHV 0.2 µm<br><b>CHV04</b> CHV 0.45 µm<br><b>CHV06</b> CHV 0.65 µm<br><b>CHV08</b> CHV 0.8 µm<br><b>CHV10</b> CHV 1.0 µm<br><b>CHV10P</b> CHV 1.0 µm (Positive Charge)<br><b>CHV30</b> CHV 3.0 µm<br><b>CHV50</b> CHV 5.0 µm | <b>A</b> Autoclavable<br><b>C</b> Cleansteam Bag Sterile Package                    | <b>1</b> 1 /pkg   | Pharmaceutical Grade  |

### Bricap L Series Capsule Filter

|   |   |   |
|---|---|---|
|  |  |  |
| Housing Type  | Capsule Format  | Inlet/Outlet  |
| <b>Blank</b> Standard   | <b>L02</b> Bricap L02   | <b>S</b> 38 mm (1 1/2") Sanitary Flange   |
| <b>K</b> Transparent  | <b>L03</b> Bricap L03   | <b>T</b> 19 mm (3/4") Sanitary Flange   |
|   | <b>L05</b> Bricap L05   | <b>K</b> 14 mm (9/16") Sanitary Flange  |
|   | <b>L10</b> Bricap L10   | <b>D</b> 25 mm (1") Hose Barb   |
|   | <b>L20</b> Bricap L20   | <b>M</b> 19 mm (3/4") Hose Barb   |
|   | <b>L30</b> Bricap L30   | <b>X</b> 16 mm (5/8") Hose Barb   |
|   |   | <b>V</b> 14 mm (9/16") Hose Barb  |
|   |   | <b>H</b> 13 mm (1/2") Hose Barb   |
|   |   | <b>Y</b> 9.6 mm (3/8") Hose Barb  |

### Bricap T Series Capsule Filter

|   |   |   |
|---|---|---|
|  |  |  |
| Capsule Format  | Inlet/Outlet  | Gauge Port Type   |
| <b>T10</b> Bricap T10   | <b>SS</b> 38 mm (1 1/2") Sanitary Flange Inlet & Outlet                           | <b>S</b> 38 mm (1 1/2") Sanitary Flange   |
| <b>T20</b> Bricap T20   | <b>SM</b> 38 mm (1 1/2") Sanitary Flange Inlet & 19 mm (3/4") Hose Barb Outlet    | <b>T</b> 19 mm (3/4") Sanitary Flange   |
| <b>T30</b> Bricap T30   |   | <b>N</b> Without Gauge Port   |

|   |   |   |   |
|---|---|---|---|
|  |  |  |  |
| Membrane Type   | Sterilization   | Quantity/Package  | Pharmaceutical Grade  |
| <b>CHV02</b> CHV 0.2 µm   | <b>A</b> Autoclavable   | <b>1</b> 1 /pkg   | Pharmaceutical Grade  |
| <b>CHV04</b> CHV 0.45 µm  | <b>C</b> Cleansteam Bag Sterile Package   |   |   |
| <b>CHV06</b> CHV 0.65 µm  |   |   |   |
| <b>CHV08</b> CHV 0.8 µm   |   |   |   |
| <b>CHV10</b> CHV 1.0 µm   |   |   |   |
| <b>CHV10P</b> CHV 1.0 µm (Positive Charge)  |   |   |   |
| <b>CHV30</b> CHV 3.0 µm   |   |   |   |
| <b>CHV50</b> CHV 5.0 µm   |   |   |   |

# Our Mission

Through Excellent Products & Sustainable Innovative Solutions,  
We Help Customers Solve Process Problems & Increase Yield.

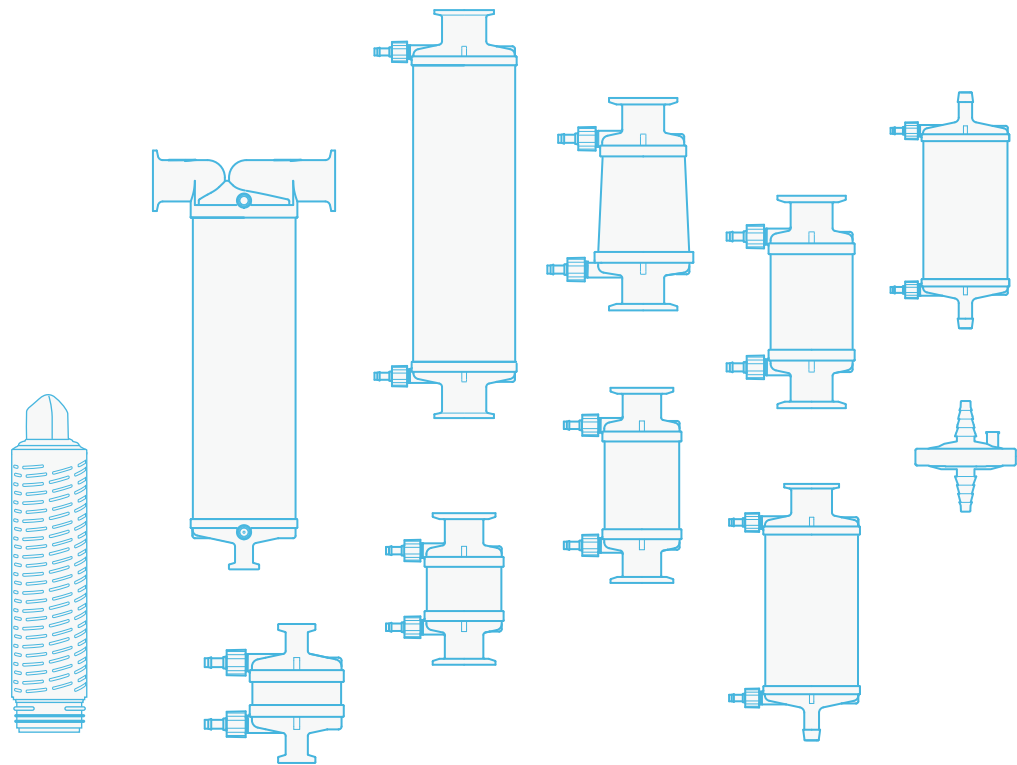

Please contact us for more information  
**Hangzhou Cobetter Filtration Equipment Co.,Ltd.**

Sales Add 13-18 F, Building 1, Zicheng International Innovation Center,  
No.39 Jincheng Road, Xiaoshan District, Hangzhou 311215, China

Factory Cobetter Park, Heshang New Material Industrial Park,  
Xiaoshan District, Hangzhou 311265, China

Tel +86 400-070-4266

Fax +86 571-87704256

[www.cobetterfiltration.com](http://www.cobetterfiltration.com)